

## 1. Characteristics

- Directional from 20 Hz to 20 kHz
  - Dipole polar pattern
  - 4.8 dB diffuse noise rejection
  - >20 dB noise rejection at the null
  - Dual sound ports
- Differential or single-ended output
- 67.5 dBA SNR
- AOP at 128 dB SPL
- 130  $\mu$ A supply current
- 3.50 x 2.65 mm<sup>2</sup> footprint
- -40 to 85 °C operating temperature

## 2. Applications

- Webcams
- AR/VR devices
- Conferencing devices
- Boom microphones
- Headsets
- Standalone microphones
- Wearables
- True wireless stereo
- OTC hearing aids
- Smart home devices
- Robotics

## 3. Description

The SKR0600 is a directional MEMS microphone that features an exceptionally high 67.5 dBA SNR. The high SNR makes the SKR0600 ideal for products that require professional-grade audio quality or extended listening ranges.

With greater integration flexibility, the SKR0600 is ideal for applications with tight space constraints, bringing the benefits of directional microphones to product categories such as TWS, hearing aids, and mobile.

The flexibility offered by the SKR0600 extends to its directional characteristics. The transducer of the SKR0600 can easily be converted to exhibit a hypercardioid or supercardioid polar pattern with the simple application of an acoustic mesh. When combined with an omnidirectional microphone, the SKR0600 can be leveraged to create ultra-high SNR beamformers.

The SKR0600 is the most flexible directional microphone offering, suited for applications where the smallest size, highest performance, or maximum directionality is desired. These directional microphones ensure high-quality audio with low background noise is obtained in products of any form factor.

## 4. Functional Block Diagram

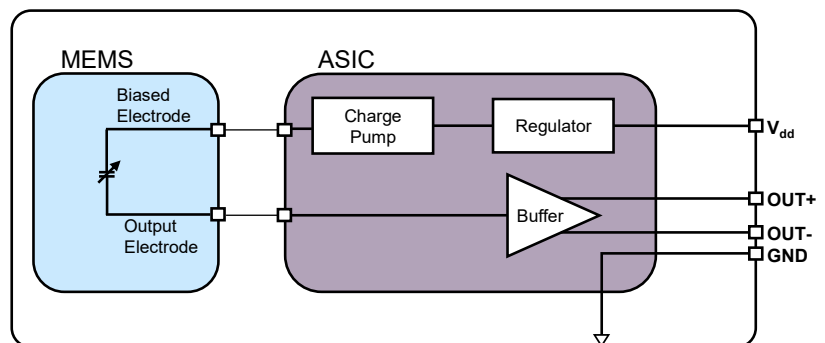

Figure 4.1: Functional block diagram

## 5. Table of Contents

1. Characteristics .....	1
2. Applications.....	1
3. Description .....	1
4. Functional Block Diagram .....	1
5. Table of Contents.....	2
6. Typical Application Circuit.....	3
7. Specifications.....	4
7.1 Acoustic and Electrical Specifications .....	4
7.2 Absolute Maximum Ratings.....	5
7.3 Specification Calculation Details .....	6
7.4 Performance Curves.....	7
8. Mechanical, Packaging, and Manufacturing Information.....	9
8.1 Mechanical Dimensions and Product Marking.....	9
8.2 Land Pattern and Solder Stencil.....	9
8.3 CAD Models .....	10
8.4 Packaging and Ordering Information .....	10
8.5 Protective Tape and Reflow Profile .....	11
9. Reliability Specifications.....	12
10. Device and Documentation Support .....	12
11. Revision History .....	12

## 6. Typical Application Circuit

The SKR0600 can be operated normally with  $V_{dd}$  from 1.6 – 2.0 V and 2.2 – 3.6 V.  $V_{dd}$  should not be set from 2.0 V – 2.2 V.

A 0.1  $\mu\text{F}$  capacitor should be placed between  $V_{dd}$  and GND as close to the microphone as possible to reduce supply noise. A capacitor,  $C_{out}$ , should be used to block the microphone's DC output from the application processing input. This capacitor creates a high-pass filter according to  $C_{out} = 1/\pi f_c R_{AP}$  (e.g. 80 nF), where  $f_c$  (e.g. 20 Hz) is the desired cutoff frequency and  $R_{AP}$  (e.g. 100 kOhm) is the application processor resistance.

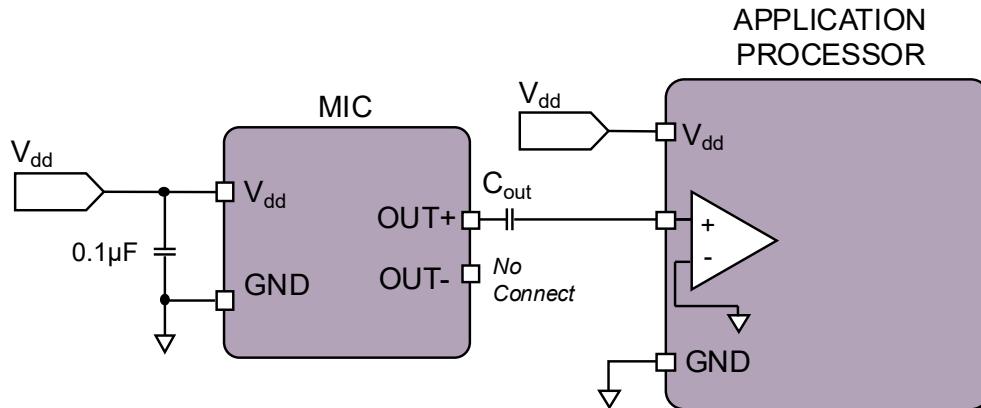

Figure 6.1: Typical single-ended application circuit

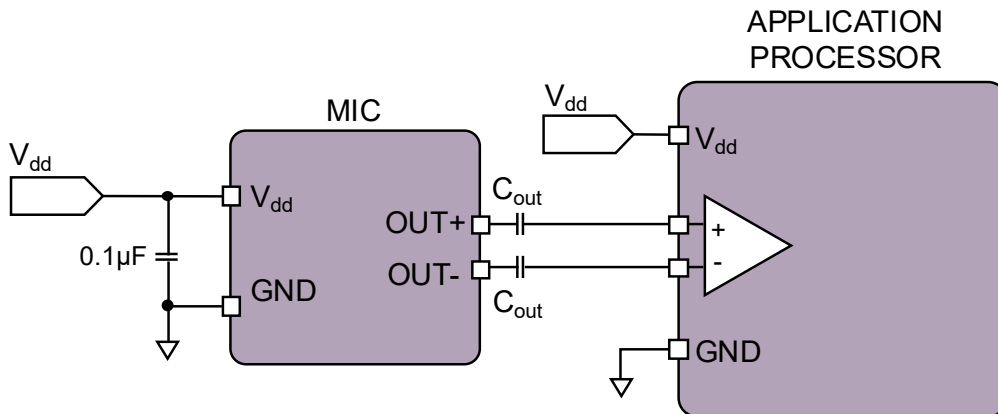

Figure 6.2: Typical differential application circuit

## 7. Specifications

### 7.1 Acoustic and Electrical Specifications

Test conditions throughout full datasheet unless otherwise indicated: 25 °C, 55 ± 20% R.H.,  $V_{dd} = 1.8$  V, single-ended, 1 m away, 10 mm acoustic path length<sup>1</sup>, no load, PCB port facing toward the loudspeaker (0° rotation).

Parameter	Symbol	Condition	Min.	Typ.	Max.	Unit
Pickup Pattern			Dipole (figure-8)			
Polarity		Increasing sound pressure at lid port	Decreasing output voltage			
		Increasing sound pressure at PCB port	Increasing output voltage			
Average Directivity Index <sup>2</sup>		Integrated from 20 Hz to 20 kHz	4.8			dB
Null Angle			90, 270			°
Supply Voltage	$V_{dd}$		1.7	1.8	2.0	V
Supply Current	$I_{dd}$	$V_{dd} = 1.8$ V	2.2			μA
Sensitivity	S	94 dB SPL, 1 kHz, Single-Ended	-32	-31	-30	dBV/Pa
		94 dB SPL, 1 kHz, Differential	-26	-25	-24	
Noise Floor		Single-Ended	-91			dBV(A)
		Differential	-85			
Signal to Noise Ratio <sup>3</sup>	SNR	20 Hz to 20 kHz, 94 dB SPL, Single-Ended	67.5			dB(A)
		20 Hz to 20 kHz, 94 dB SPL, Differential	67.0			
Total Harmonic Distortion <sup>4</sup>	THD	94dB SPL, 1kHz	<0.1			%
		1% THD, 1 kHz	108			
Acoustic Overload Point	AOP	10% THD, 1 kHz	128			dB SPL
Resonant Frequency	Fres		3.3			kHz
Phase Response		75 Hz	0			°
		1 kHz	-19			
		3 kHz	-96			
Group Delay		250 Hz	68			μs
		600 Hz	55			
		1 kHz	54			
		4 kHz	96			
Power Supply Rejection Ratio	PSRR	200 mV <sub>pp</sub> sine wave on $V_{dd}$ at 1 kHz, Single-Ended	67			dB
		200 mV <sub>pp</sub> sine wave on $V_{dd}$ at 1 kHz, Differential	62			
Power Supply Rejection	PSR+N	200 mV <sub>pp</sub> 7/8 duty cycle rectangular waveform @ 217 Hz on $V_{dd}$ , A-weighted, BW = 22.4kHz, Single-Ended	-85			dBV(A)
		200 mV <sub>pp</sub> 7/8 duty cycle rectangular waveform @ 217 Hz on $V_{dd}$ , A-weighted, BW = 22.4kHz, Differential	-84			
DC Voltage Output		$V_{dd} = 1.8$ V	0.836			V
DC Offset		OUT+ to OUT-	±10			mV
Output Impedance	$Z_{out}$		100			Ω
Startup Time		Sensitivity within 1 dB of final value, outputs AC coupled	15			ms

Table 7.1: Acoustic and electrical specifications

<sup>1</sup> The acoustic path length is the minimum distance a soundwave must travel between the ports of the microphone. See [Acoustic Path Length Definition](#) for details.

<sup>2</sup> The directivity index is a measure of directionality based on the ratio of direct sound to diffuse sound captured. See [Directivity Index Calculation](#) for details.

<sup>3</sup> A directional microphone has a non-flat frequency response, as such the SNR must be calculated for the entire frequency range. See [SNR Calculation](#) for details.

<sup>4</sup> To calculate the THD of a microphone with a non-flat frequency response, the frequency response must first be equalized. See [THD Calculation](#) for details.

## 7.2 Absolute Maximum Ratings

Stresses at or above the Absolute Maximum Ratings could permanently damage the devices.

Parameter	Absolute Maximum Rating	Unit
V <sub>dd</sub> to GND	5.0	V
Input Current	±5	mA
Storage Temperature	-40 to 125	°C
Operating Temperature	-40 to 105	°C

*Table 7.2: Absolute maximum ratings*

## 7.3 Specification Calculation Details

### Acoustic Path Length Definition

The acoustic path length is the minimum distance a sound wave must travel around the microphone package between the two ports. The SKR0600 is designed to perform best with path lengths found in end-products, which are typically 10 mm or greater. All specifications are measured with a standard 10 mm path length, the minimum recommended path length when integrating the device.

### Directivity Index and Average Directivity Index Calculation

The **directivity index** (DI) measures the ratio of the microphone output for a sound positioned directly in front of the microphone ( $\theta = 0^\circ$ ) versus sound with the same amount of total acoustic power coming from all directions equally. The directivity index at each frequency is calculated with the equation below.

$$DI = 10 \log_{10} \left( 4 \frac{\text{amplitude}(\theta = 0)^2 \left[ \frac{V^2}{Pa^2} \right]}{\int_0^{2\pi} \text{amplitude}(\theta)^2 \left[ \frac{V^2}{Pa^2} \right] |\sin \theta| d\theta} \right)$$

Equation 7.1: Directivity Index

The average directivity index is calculated by logarithmically weighing the directionality index at each frequency and then taking the average of these weighted values from 20 Hz to 20 kHz.

### SNR Calculation

The SNR of a directional microphone with a non-flat frequency response must be calculated differently than the typical method used for omnidirectional microphones that have a flat frequency response. Instead of only using the 1 kHz sensitivity, we must consider the microphone's performance across all frequencies. The electrical noise at each frequency (in  $V^2/Hz$ ) should be divided by the corresponding sensitivity squared (in  $V^2/Pa^2$ ) to obtain the input-referred acoustic noise (in  $Pa^2/Hz$ ). Then, the acoustic noise is A-weighted by multiplying it by the A-weighting factor ( $A_w$ ) and this A-weighted acoustic noise is integrated over the full audio bandwidth and converted to an equivalent sound pressure level (dBA SPL) by dividing by the reference pressure ( $P_{ref}=20 \mu Pa$ ). Finally, the SNR is calculated by subtracting the integrated input referred noise from 94 dB SPL. The equation for the calculation is shown below.

$$SNR = 94 - 10 \log_{10} \left( \frac{1}{P_{ref}^2 [Pa^2]} \int_{20Hz}^{20kHz} \frac{\text{noise} \left[ \frac{V^2}{Hz} \right]}{\text{sensitivity} \left[ \frac{V^2}{Pa^2} \right]} A_w^2 df [Hz] \right)$$

Equation 7.2: Full-spectrum SNR calculation

### THD Calculation

THD is calculated by playing an acoustic sine wave at a specific sound pressure level and frequency and dividing the sum of the powers of the harmonic components of the captured signal by the power of the fundamental frequency. To calculate the THD of a microphone with a non-flat frequency response, the response must first be equalized to equally weigh the fundamental frequency and its respective harmonics.

For more information on these calculations, refer to the app note: [AN-110: Attributes of Soundskrit Directional Microphones](#).

### 7.4 Performance Curves

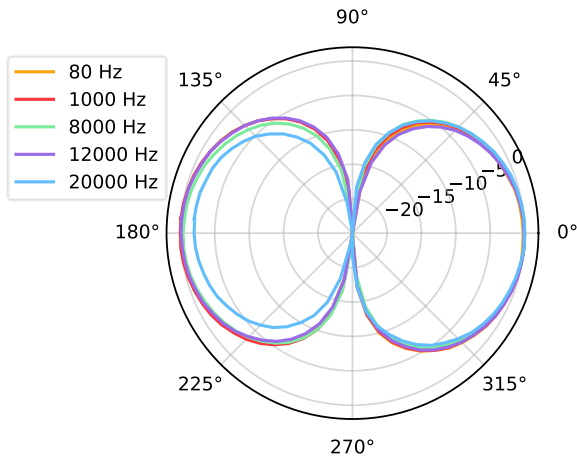

Figure 7.1: Pickup pattern vs. frequency

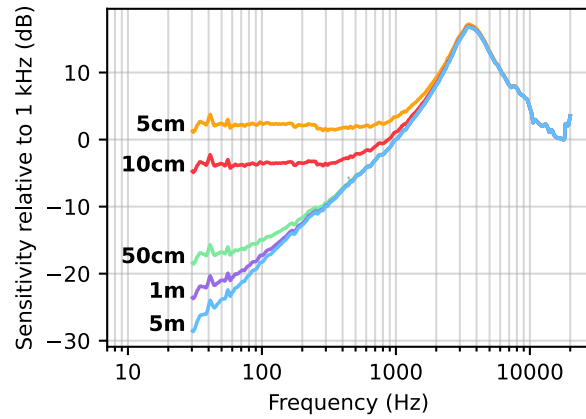

Figure 7.2: Typical magnitude response<sup>5</sup>

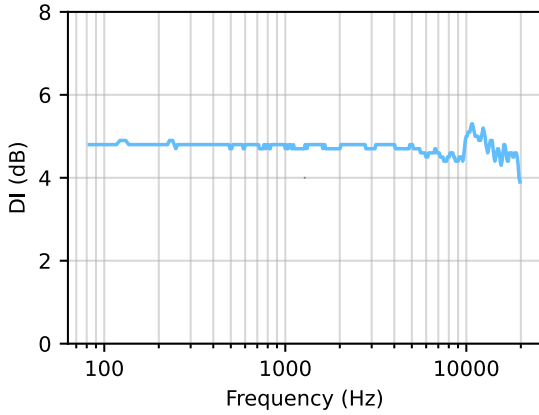

Figure 7.3: Directivity index vs frequency

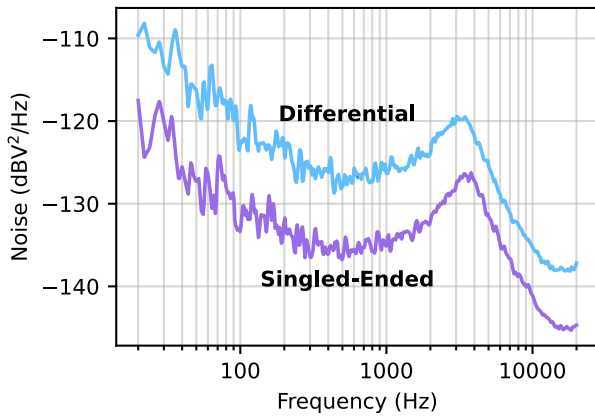

Figure 7.4: Typical noise floor

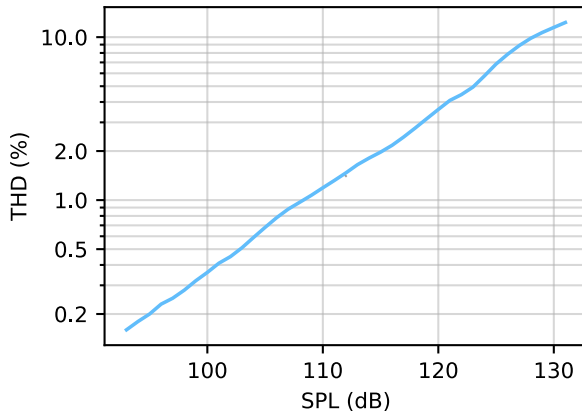

Figure 7.5: Typical THD (1 kHz) vs SPL

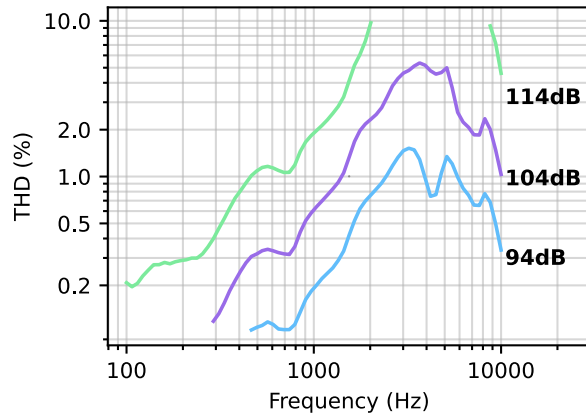

Figure 7.6: THD vs frequency

<sup>5</sup> The increased bass response at close distances is known as the 'Proximity Effect.' See [AN-110](#) for details.

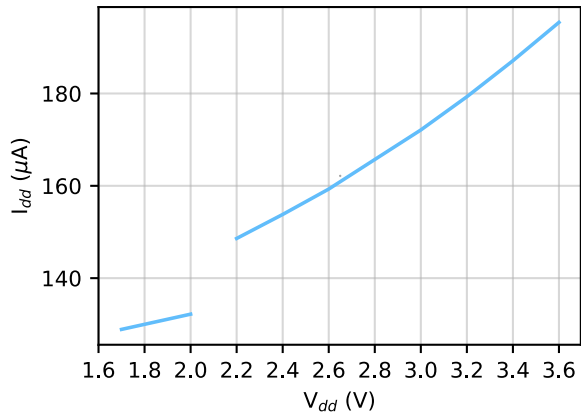

Figure 7.7: Supply current vs input voltage

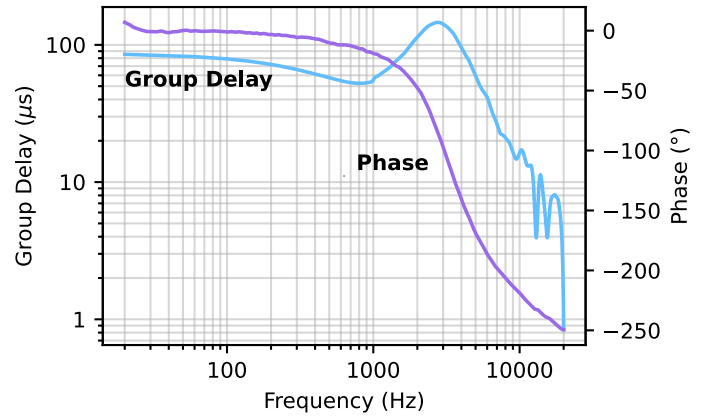

Figure 7.8: Typical phase and group delay

## 8. Mechanical, Packaging, and Manufacturing Information

### 8.1 Mechanical Dimensions and Product Marking

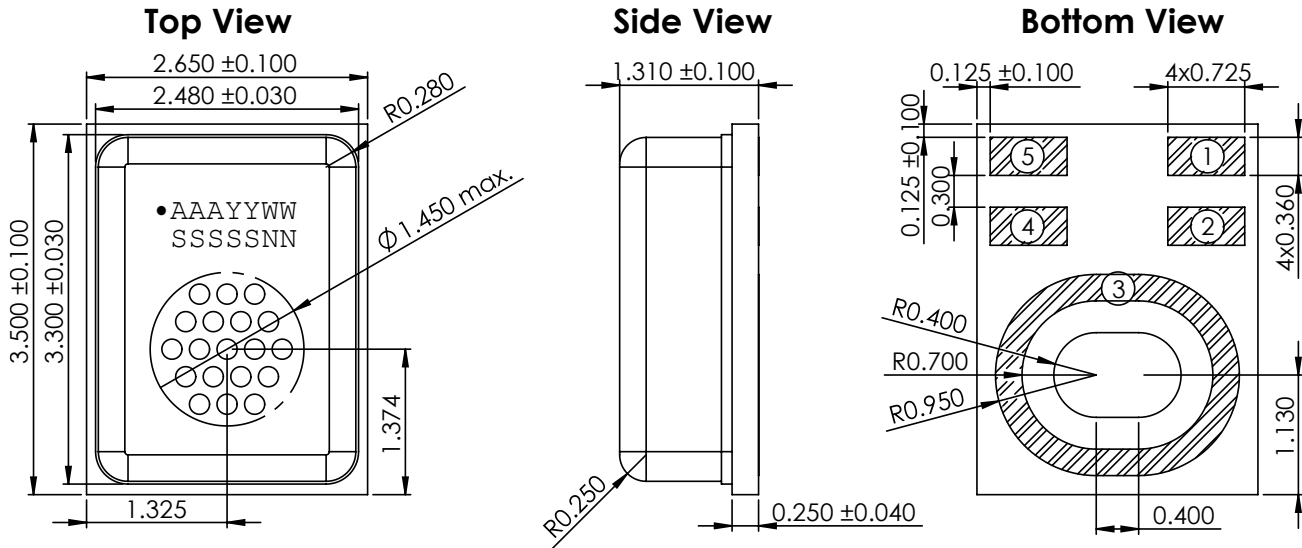

Figure 8.1: Mechanical drawings (mm)

Table 8.1: Mechanical specifications

Item	Dimensions (mm)
Length	3.500 ± 0.100
Width	2.650 ± 0.100
Height	1.310 ± 0.100
Lid Port Array OD	1.450 max
Bottom Acoustic Port	1.200 x 0.800 ± 0.050

Table 8.2: Pinout

Pin #	Pin Name	Description
1	OUT+	Non-Inverted Output Signal
2	OUT-	Inverted Output Signal
3, 4	GND	Ground
5	V <sub>dd</sub>	Power Supply

Table 8.3: Product marking

Marking	Description
AAA	Model Code: SKR0AAA
YY	Year 20YY
WW	Week WW of the year
SSSSSNN	Internal Codes

### 8.2 Land Pattern and Solder Stencil

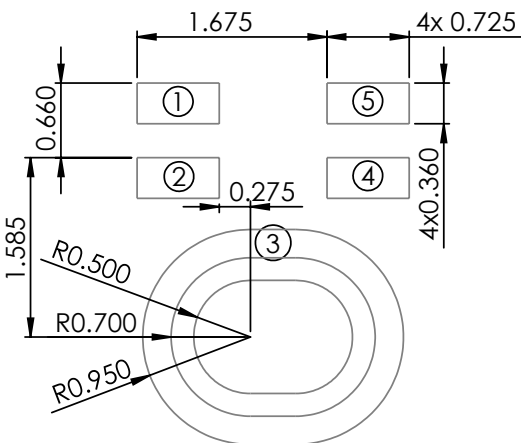

Figure 8.2 Example land pattern (mm)

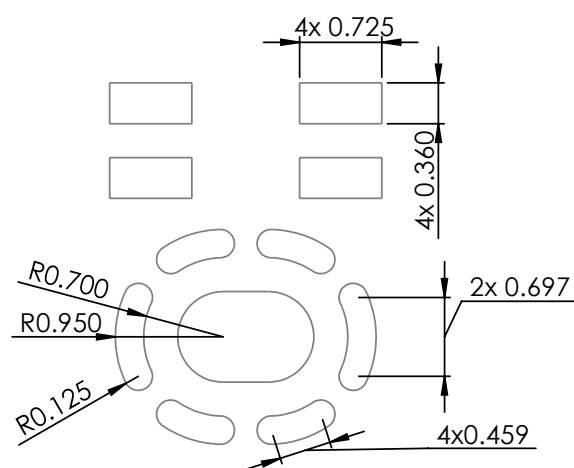

Figure 8.3 Example solder stencil pattern (mm)

### 8.3 CAD Models

CAD models and KiCAD layout and footprint files are available here: [STEP File and KiCAD](#).

### 8.4 Packaging and Ordering Information

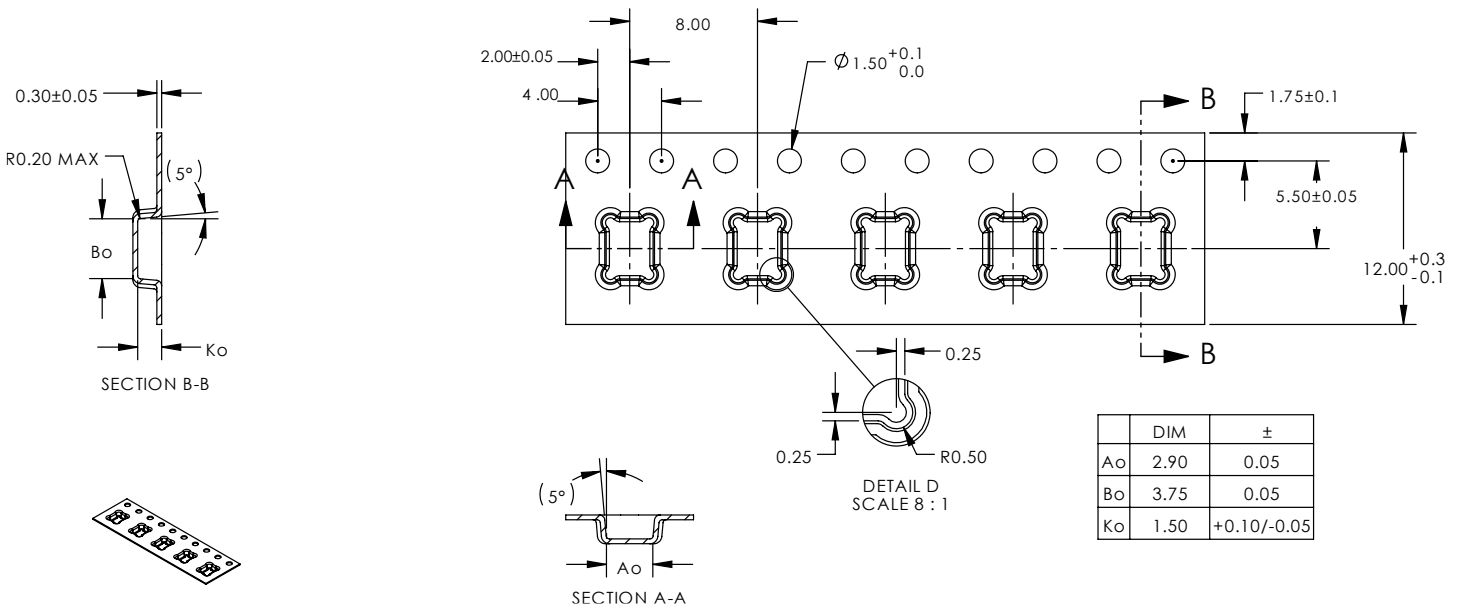

Figure 8.3 Reel dimensions (mm)

Table 8.3: Ordering Information

Model Number	Reel Diameter	Quantity per Reel
SKR0600-7	7"	1300
SKR0600-13	13"	5000

Table 8.4: Packaging Information

Component	Surface Resistance ( $\Omega$ )
Reel	$10^5$ to $10^{12}$
Carrier Tape	$10^5$ to $10^{11}$
Cover Tape	$10^5$ to $10^{12}$

## 8.5 Protective Tape and Reflow Profile

Figure 8.5 shows the recommended reflow profile for soldering the microphone. The reflow profile is based on the standard J-STD-020D. The microphone has a moisture sensitivity level (MSL) of Class 1.

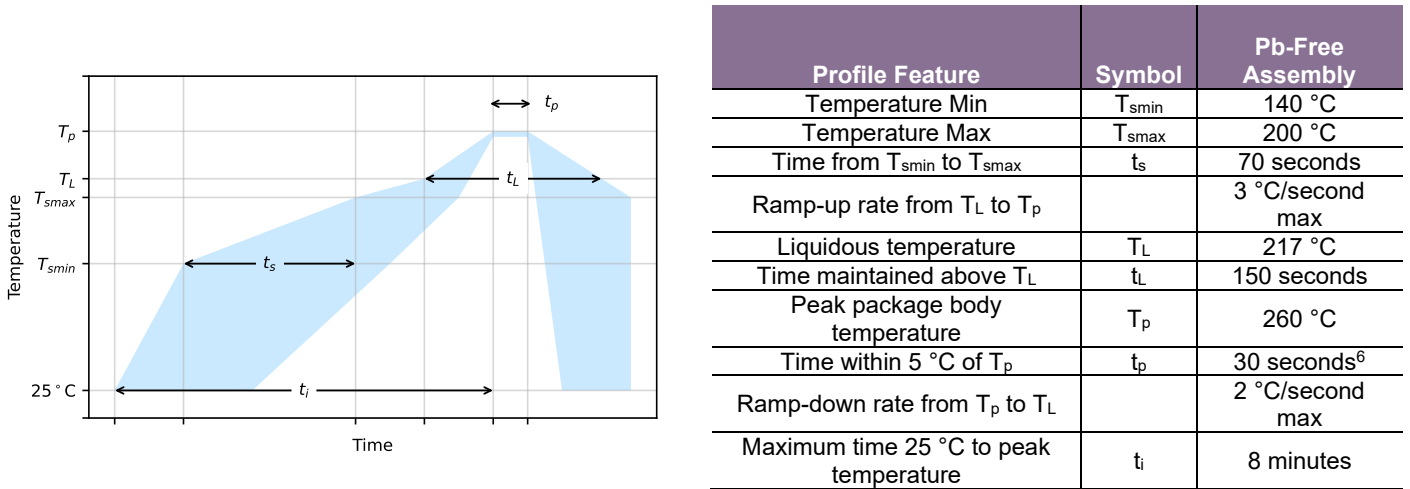

Figure 8.5: Reflow profile

The microphone is packaged with a layer of reflow-compatible Kapton tape covering the lid port. This tape protects the microphone during reflow and assembly and should only be removed at the latest stage possible in the assembly process. Do not remove the Kapton tape prior to soldering the microphone or nearby components. To remove the Kapton tape, use tweezers to catch the edge of the tape and peel the tape off.

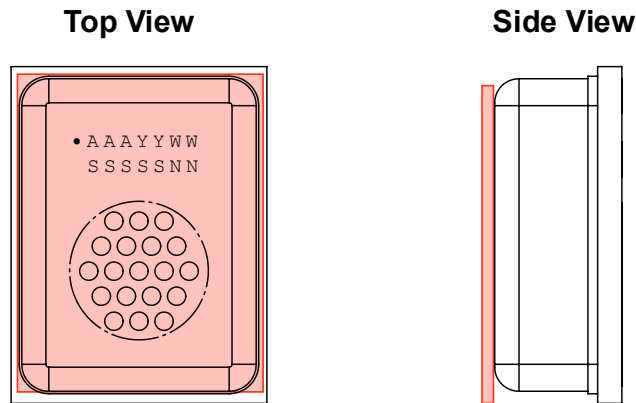

Figure 8.6: Mechanical drawing with protective tape

The MEMS microphones should be handled using industry-standard pick-and-place equipment or appropriate manual handling procedures. To minimize damage, please carefully follow the guidelines below:

- Use the pick-up area shown in Figure 8.6.
- Do not apply a vacuum or high pressure over lid or PCB acoustic port holes.
- Do not apply air blow and ultrasonic cleaning procedures over lid or PCB acoustic port holes.
- Do not perform board washing or cleaning procedures after the reflow process.
- Do not expose the lid or PCB acoustic port holes to harsh chemicals.
- Do not directly expose the lid or PCB acoustic port holes to solder fumes or vapor phase soldering.
- Do not apply a vacuum when packing parts in sealed bags at a suction flow rate faster than 0.85 CFM.

<sup>6</sup> Tolerance for peak profile temperature ( $T_p$ ) is defined as a supplier minimum and a user maximum.

## 9. Reliability Specifications

The microphone sensitivity must not deviate by more than 1 dB from the initial value after three reflow cycles for the reflow test and no more than 3 dB for the other tests.

Test	Test Condition	Standard
ESD-CDM	3 discharges of $\pm 500$ V with direct contact to I/O pins	JEDEC-JS002
ESD-HBM	3 discharges of $\pm 2$ kV with direct contact to I/O pins	JEDEC-JS001
ESD-LID/GND	3 discharges of $\pm 8$ kV with direct contact to lid while unit is under bias	IEC-61000-4-2
Free Fall	Microphone put in a 150g block, drop from 1.5m onto concrete floor, 4 drops for each surface and corner, total 40 drops	IEC 60068-2-32
High Temperature Bias	+125 °C for 1,000 hours under bias	JESD22 A-108F
High Temperature Storage	+125 °C for 1,000 hours	JESD22 A-103E
Low Temperature Bias	-40 °C for 1,000 hours under bias	JESD22 A-108F
Low Temperature Storage	-40 °C for 1,000 hours	JESD22-A119A
Mechanical Shock	5 shocks of 10,000 g / 0.1 msec in each direction of $\pm x$ , $\pm y$ , $\pm z$ , 30 shocks in total	IEC 60068-2-27
Reflow	3 reflow cycles with +260 °C peak temperature	IPC-JEDEC J-STD-020E
Temperature Humidity Bias	+85 °C/85% R.H. for 1,000 hours under bias	JESD22-A101D
Thermal Shock	100 cycles, air-to-air, -40 °C to +125 °C, 15 minutes soak	JESD22.A104E
Tumble	Microphone put in a 150g block, drop from 1m onto steel base, rotation speed 10-11 times/min, 300 drops	IEC 60068-2-32
Vibration	4 cycles of 4 minutes each in each x, y, z axis from 20 Hz to 2000 Hz with peak acceleration of 20 G	MIL-STD-883E-2007-2-A

Table 9.1: Reliability specifications

## 10. Device and Documentation Support

Supporting application notes are available on our [application notes page](#).

## 11. Revision History

Revision Label	Revision Date	Sections Revised
-	January 2025	Official release
A	June 2025	Updated product marking
B	October 2025	Updated sensitivity to -25dBV/Pa



Soundskrit developed the first high-performance directional MEMS microphone on the market, leveraging years of research in bio-inspired MEMS based on how spiders and other insects hear in nature. Combined with Soundskrit's in-house audio processing algorithms, these directional microphones can capture and isolate any sound in an environment with a fraction of the size, power, and computation required by traditional omnidirectional-based microphone arrays.

Soundskrit was founded in 2019 and is headquartered in Montreal, Quebec with an R&D facility in Ann Arbor, Michigan.

