

## 1. Characteristics

- Dipole microphone
  - 65 dBA SNR
  - 4.8 dB DI
- Omnidirectional microphone
  - 68 dBA SNR
- Integrated meshes for IP58
- Pre-tested for >20 dB sealing
- Ports integrated on single surface
- 235  $\mu$ A supply current
- 16.40 x 8.10 x 7.00 mm<sup>3</sup>

## 2. Applications

- AR & VR Devices
- Conferencing Devices
- Webcams & Security Cameras
- Headsets
- Intercoms & Video Doorbells
- Voice Badges
- Smart Home Devices

## 4. Design Features

## 3. Description

The SKM1600 is a plug-and-play analog microphone module for consumer electronics. The module incorporates an [SKR0600 dipole microphone](#) with an omnidirectional MEMS microphone. All acoustic ports are conveniently positioned on a single surface and protected by an ingress-resistant acoustic mesh, streamlining integration into devices.

When combined with digital signal processing, the omnidirectional-dipole microphone pair enables robust, polar pattern selection (omnidirectional, dipole, cardioid, etc.) with a high signal-to-noise ratio. The omnidirectional microphone acoustic port is positioned relative to the directional microphone acoustic ports to ensure optimal beamforming performance.

The SKM1600 enables customers to achieve high-quality audio pickup quickly and efficiently, making it ideal for applications where premium sound capture and directional flexibility are essential.

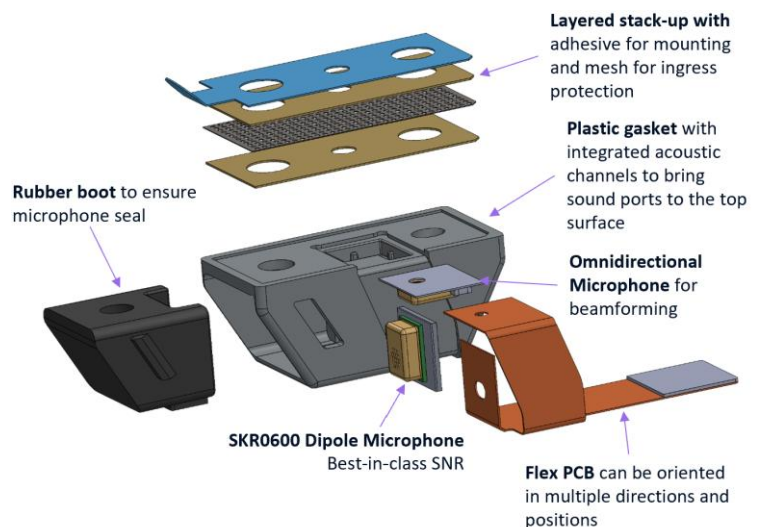
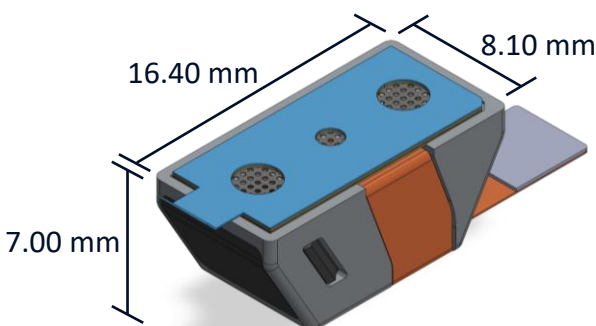

## 5. Table of Contents

1. Characteristics .....	1
2. Applications.....	1
3. Description .....	1
4. Design Features.....	1
5. Table of Contents.....	2
6. Typical Application Circuit.....	3
7. Specifications.....	4
7.1 Electrical Specifications.....	4
7.2 Dipole Microphone Specifications .....	4
7.3 Omnidirectional Microphone Specifications.....	5
7.4 Specification Calculation Details .....	5
Directivity Index and Average Directivity Index Calculation .....	5
SNR Calculation .....	6
THD Calculation.....	6
7.5 Absolute Maximum Ratings.....	6
7.6 Performance Curves.....	7
8. Mechanical Drawings and Integration Design .....	9
8.1 Mechanical Drawings and Pinout .....	9
8.2 CAD Models .....	9
8.3 Installation .....	9
8.4 Packaging and Ordering Information.....	10
9. Reliability Specifications.....	10
10. Additional Support.....	11
11. Revision History .....	11

## 6. Typical Application Circuit

The SKM1600 is operated with  $V_{dd}$  from 1.6 - 2.0 V and 2.2 - 3.6 V.  $V_{dd}$  should not be set from 2.0V - 2.2 V.

A 0.1  $\mu\text{F}$  capacitor between  $V_{dd}$  and GND is included on the flex cable of the module to reduce supply noise.

A capacitor  $C_{out}$  should be used to block each microphone's output DC from the application processing input. This capacitor creates a high-pass filter according to  $C_{out} = 1/\pi f_c R_{AP}$  (e.g. 80 nF), where  $f_c$  (e.g. 20 Hz) is the desired cutoff frequency and  $R_{AP}$  (e.g. 100 kOhm) is the application processor resistance.

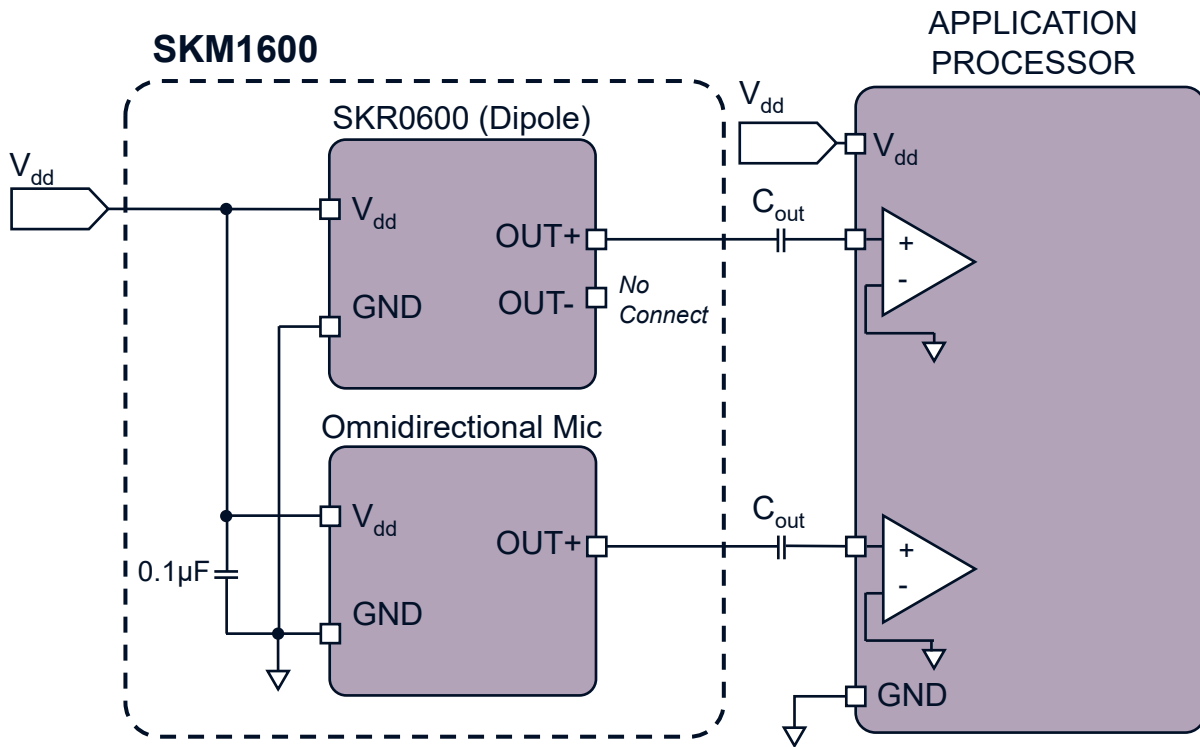

Figure 6.1: Typical application circuit

## 7. Specifications

Test conditions throughout full datasheet unless otherwise indicated: 25 °C, 55 ± 20% R.H.,  $V_{dd} = 1.8\text{ V}$ , 1 m away, no load, flex PCB facing toward loudspeaker and defined as 0° (front).

### 7.1 Electrical Specifications

Parameter	Symbol	Condition	Min.	Typ.	Max.	Unit
Supply Voltage	$V_{dd}$		1.7	1.8	2.0	V
			2.2	2.8	3.6	
Supply Current	$I_{dd}$	$V_{dd} = 1.8\text{ V}$		235		µA

### 7.2 Dipole Microphone Specifications

The SKM1600 incorporates a SKR0600 dipole microphone configured in a single-ended output.

Parameter	Symbol	Condition	Min.	Typ.	Max.	Unit
Pickup Pattern			Dipole			
Polarity		Increasing sound pressure at back (out-of-phase with omnidirectional microphone)	Decreasing output voltage			
		Increasing sound pressure at front (phase-aligned with omnidirectional microphone)	Increasing output voltage			
Average Directivity Index		Integrated from 20 Hz to 20 kHz	4.8			dB
Null Angle			90, 270			°
Sensitivity	S	94 dB SPL, 1 kHz	-33.5	-32.5	-31.5	dBV/Pa
Noise Floor		A-weighted 20Hz to 20kHz	-93.5			dBV(A)
Signal to Noise Ratio <sup>1</sup>	SNR	20 Hz to 20 kHz, 94 dB SPL	65.0			dB(A)
Total Harmonic Distortion <sup>2</sup>	THD	94dB SPL, 1kHz	<0.1			%
		1% THD, 1 kHz	113			
Acoustic Overload Point	AOP	10% THD, 1 kHz	128			dB SPL
Resonant Frequency	Fres		3			kHz
Power Supply Rejection Ratio	PSRR	200 mV <sub>pp</sub> sine wave on $V_{dd}$ at 1 kHz	67			dB
Power Supply Rejection	PSR+N	200 mV <sub>pp</sub> 7/8 duty cycle rectangular waveform @ 217 Hz on $V_{dd}$ , A-weighted, BW = 22.4kHz	-89			dBV
DC Voltage Output		$V_{dd} = 1.8\text{ V}$	.836			V
Output Impedance	$Z_{out}$		100			Ω
Startup Time		Sensitivity within 1 dB of final value, outputs AC coupled	15			ms

<sup>1</sup> A directional microphone has a non-flat frequency response, as such the SNR must be calculated for the entire frequency range. See [SNR Calculation](#) for details.

<sup>2</sup> To calculate the THD of a microphone with a non-flat frequency response, the frequency response must first be equalized. See [THD Calculation](#) for details.

### 7.3 Omnidirectional Microphone Specifications

The SKM1600 incorporates Merry MMA206-019 omnidirectional microphone configured in a single-ended output.

Parameter	Symbol	Condition	Min.	Typ.	Max.	Unit
Pickup Pattern			Omnidirectional			
Polarity		Increasing sound pressure at (PCB) port	Increasing output voltage			
Average Directivity Index		Integrated from 20 Hz to 20 kHz		0.2		dB
Sensitivity	S	94 dB SPL, 1 kHz	-40	-39	-38	dBV/Pa
Noise Floor				-106		dBV(A)
Signal to Noise Ratio	SNR	20 Hz to 20 kHz, 94 dB SPL		68		dB(A)
Total Harmonic Distortion	THD	94dB SPL, 1kHz		<0.1		%
		1% THD, 1 kHz		123		dB SPL
Acoustic Overload Point	AOP	10% THD, 1 kHz		130		
Resonant Frequency	Fres			17		kHz
Power Supply Rejection Ratio	PSRR	200 mV <sub>pp</sub> sine wave on V <sub>dd</sub> at 1 kHz		68		dB
Power Supply Rejection	PSR+N	200 mV <sub>pp</sub> 7/8 duty cycle rectangular waveform @ 217 Hz on V <sub>dd</sub> , A-weighted, BW = 22.4kHz		-95		dBV
DC Voltage Output		V <sub>dd</sub> = 1.8 V		0.87		V
Output Impedance	Z <sub>out</sub>				400	Ω
Startup Time		Time to sensitivity within 1 dB of final value, outputs AC coupled		30		ms

### 7.4 Specification Calculation Details

#### Directivity Index and Average Directivity Index Calculation

The directivity index measures the ratio of the microphone output for a sound positioned directly in front of the microphone ( $\theta = 0^\circ$ ) versus sound with the same amount of total acoustic power coming from all directions equally. The directivity index at each frequency is calculated with the equation below.

$$DI = 10 \log_{10} \left( 4 \frac{\text{amplitude}(\theta = 0)^2 \left[ \frac{V^2}{Pa^2} \right]}{\int_0^{2\pi} \text{amplitude}(\theta)^2 \left[ \frac{V^2}{Pa^2} \right] |\sin \theta| d\theta} \right)$$

Equation 7.1: Directivity Index

The average directivity index is calculated by logarithmically weighting the directionality index at each frequency and then taking the average of these weighted values from 20 Hz to 20 kHz. For more information, refer to the app note: [AN-110: Attributes of Soundskrit Directional Microphones](#).

## SNR Calculation

The SNR of a directional microphone with a non-flat frequency response must be calculated differently than the typical method used for omnidirectional microphones that have a flat frequency response. Instead of only using the 1 kHz sensitivity, the electrical noise of the microphone at each frequency (units of V<sup>2</sup>/Hz) must be divided by the corresponding sensitivity squared at each frequency (units of V<sup>2</sup>/Pa<sup>2</sup>) to obtain the input referred acoustic noise at each frequency (units of Pa<sup>2</sup>/Hz). Then, the acoustic noise is A-weighted by multiplying it by the A-weighting factor (A<sub>w</sub>) and this A-weighted acoustic noise is integrated over the full audio bandwidth and converted to an equivalent sound pressure level (dBV(A) SPL) by dividing by the reference pressure (P<sub>ref</sub>=20 μPa). Finally, the SNR is calculated by subtracting the integrated input referred noise from 94 dB SPL. The equation for the calculation is shown below. For more information, refer to the app note: [AN-110: Attributes of Soundskrit Directional Microphones](#).

$$SNR = 94 - 10 \log_{10} \left( \frac{1}{P_{ref}^2 [Pa^2]} \int_{20Hz}^{20kHz} \frac{noise \left[ \frac{V^2}{Hz} \right]}{sensitivity \left[ \frac{V^2}{Pa^2} \right]} A_w^2 df [Hz] \right)$$

Equation 7.2: Full-spectrum SNR calculation

## THD Calculation

THD is calculated by playing an acoustic sine wave at a specific sound pressure level and frequency and dividing the sum of the powers of the harmonic components of the captured signal by the power of the fundamental frequency. To calculate the THD of a microphone with a non-flat frequency response, the response must first be equalized to equally weigh the fundamental frequency and its respective harmonics. For more information on equalization and THD calculation, refer to the app note: [AN-110: Attributes of Soundskrit Directional Microphones](#).

## 7.5 Absolute Maximum Ratings

Meeting or exceeding the conditions listed as Absolute Maximum Ratings could permanently damage the devices. Operating the devices at these ratings could impact device reliability.

Parameter	Absolute Maximum Rating	Unit
V <sub>dd</sub> to GND	5.0	V
Input Current	±5	mA
Storage Temperature	-40 to 85	°C
Operating Temperature	-40 to 85	°C

## 7.6 Performance Curves

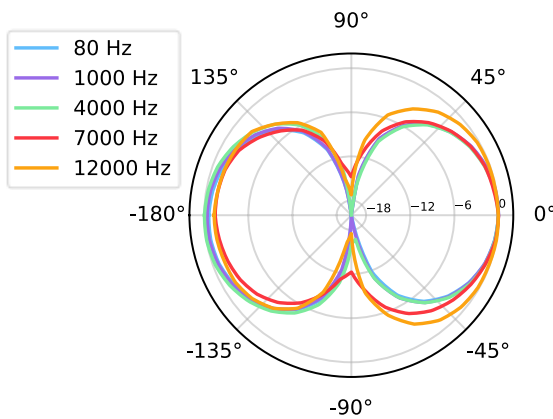

Figure 7.1: Polar pattern (dipole)

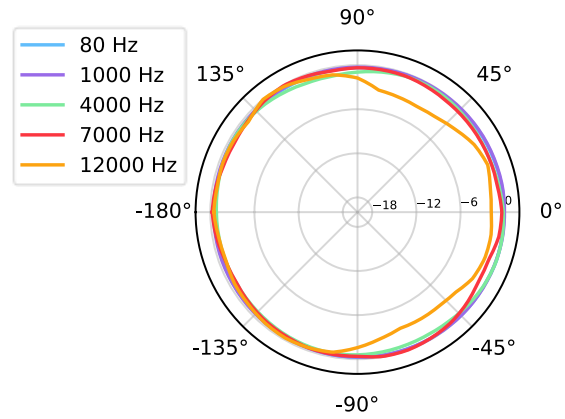

Figure 7.2: Polar pattern (omni)

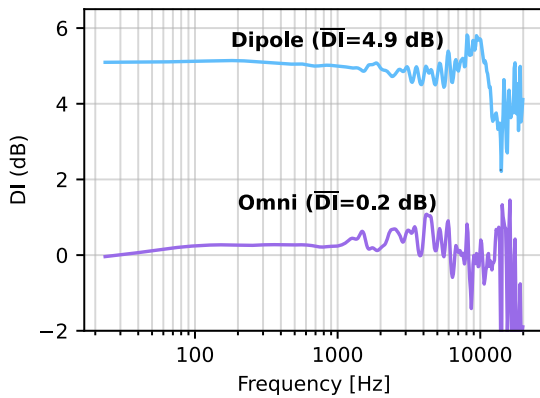

Figure 7.3: Directionality index vs frequency

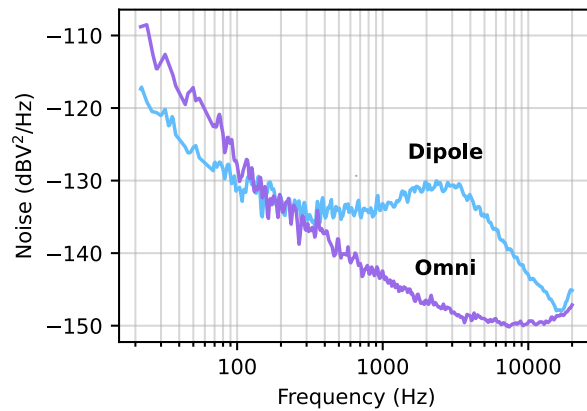

Figure 7.4: Noise floor

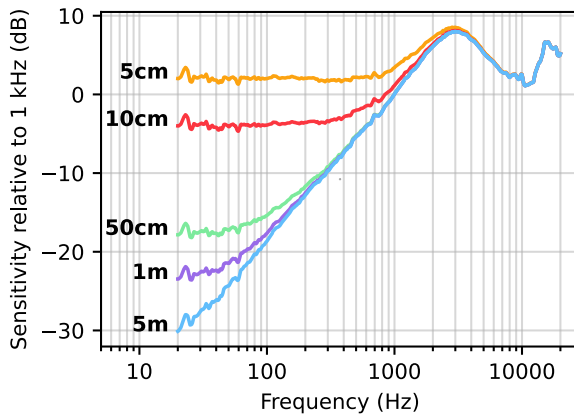

Figure 7.5: Magnitude response<sup>3</sup> (dipole)

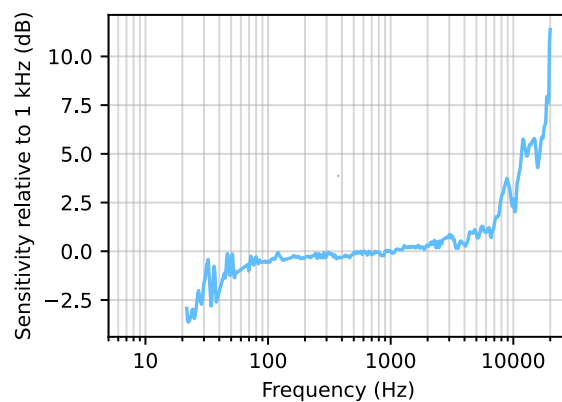

Figure 7.6: Magnitude response (omni)

<sup>3</sup> The increased bass response at close distances is known as the 'Proximity Effect.' See [AN-110](#) for details.

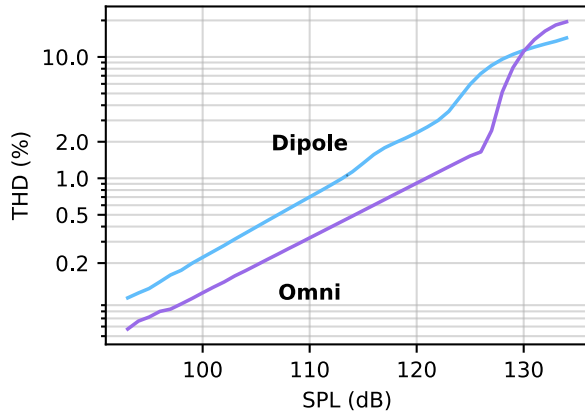

Figure 7.7: 1 kHz THD vs SPL

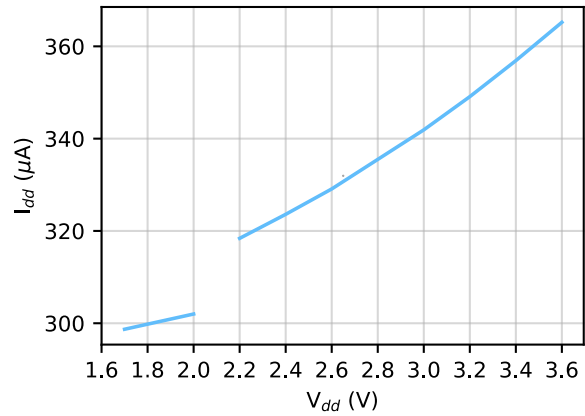

Figure 7.8: Supply Current vs Input Voltage

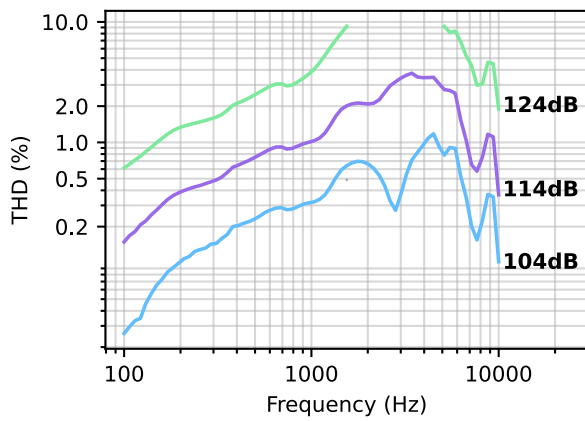

Figure 7.9: THD vs Frequency (dipole)

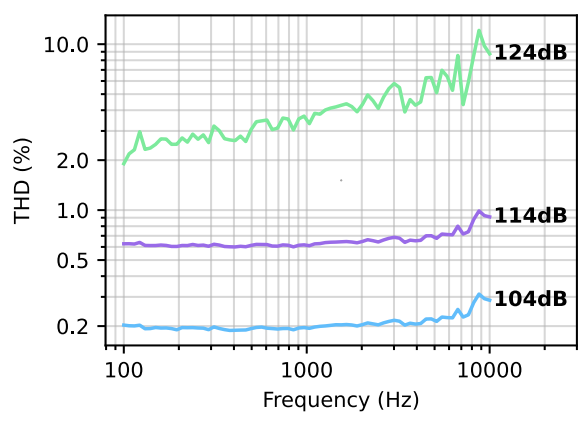

Figure 7.10: THD vs Frequency (omni)

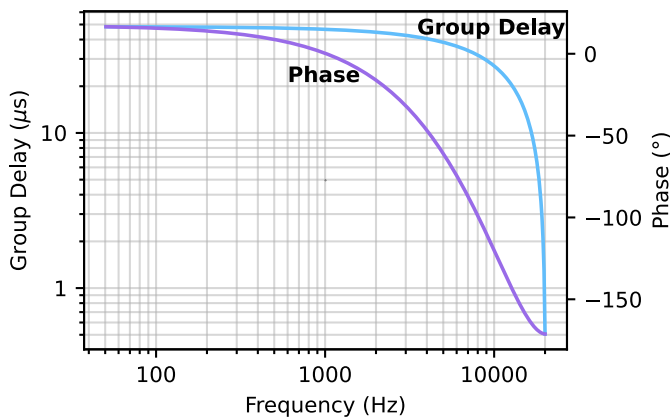

Figure 7.11: Phase and group delay (dipole)

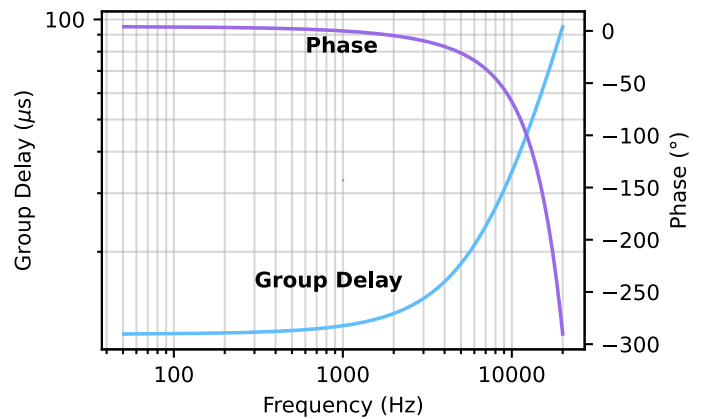

Figure 7.12: Phase and group delay (omni)

## 8. Mechanical Drawings and Integration Design

### 8.1 Mechanical Drawings and Pinout

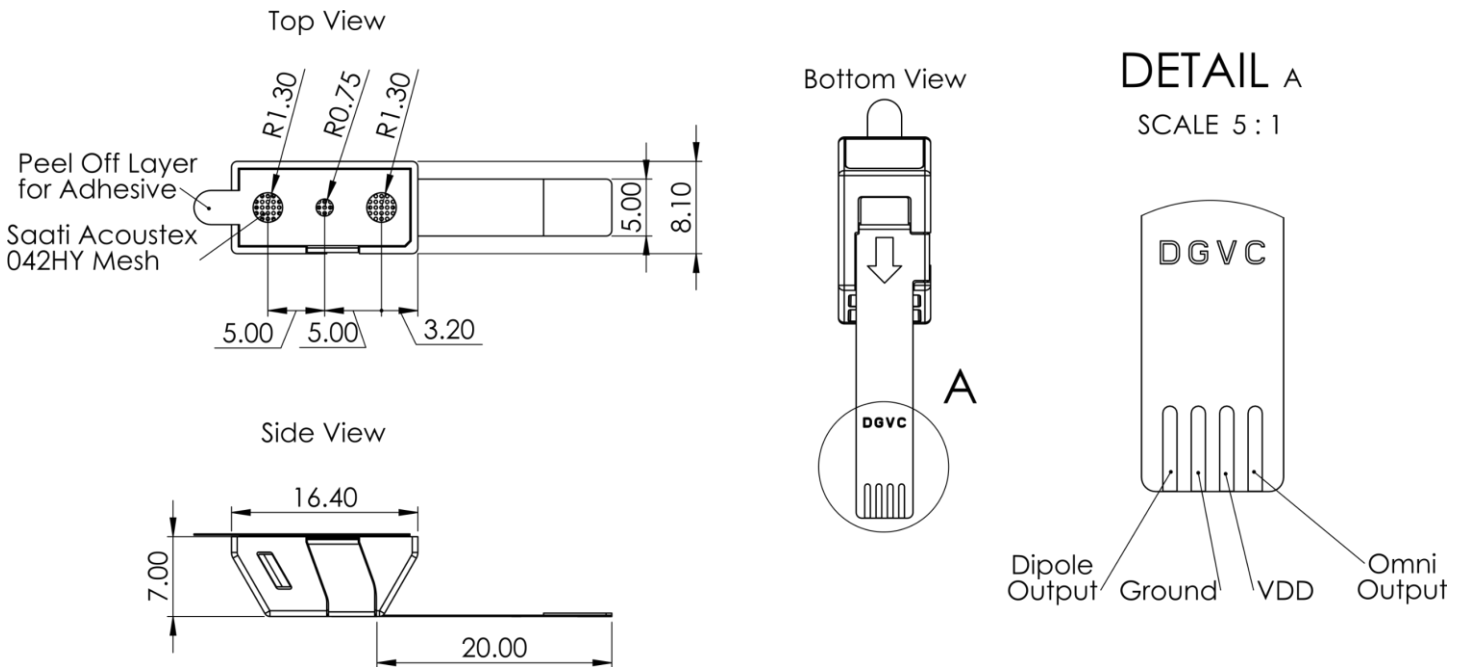

Figure 8.1: Mechanical drawings (mm)

The SKM1600 incorporates a SAATI Acoustex 042HY mesh placed above all acoustic ports for IP58 (ingress and water immersion protection).

### 8.2 CAD Models

The CAD model for the module is available here: [STEP File](#).

### 8.3 Installation

The product shell should include two acoustic ports with a diameter  $\geq 1.8\text{mm}$  for the dipole microphone and a center port with a diameter  $\geq 1\text{mm}$  for the omnidirectional microphone to achieve the specifications listed in this datasheet. The product shell should also include a raised lip that the module fits into to help align the module during installation. To install the SKM1600, remove the peel-off layer to expose the adhesive, then align the module's acoustic ports to the device shell ports and press firmly for a secure acoustic seal. The adhesive will create an acoustic seal between the module ports and the product ports. This is an example of a mating connector [HFW4R-1STE1H1LF](#)

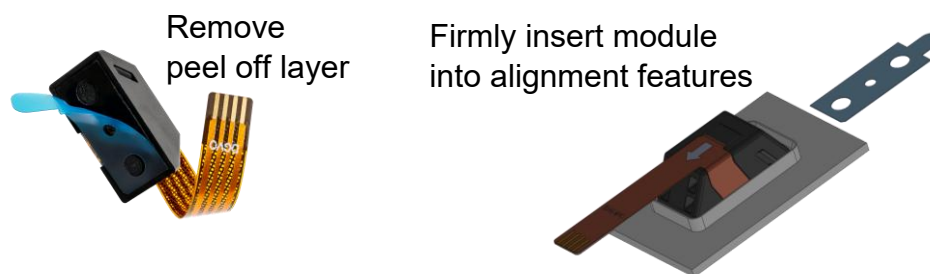

## 8.4 Packaging and Ordering Information

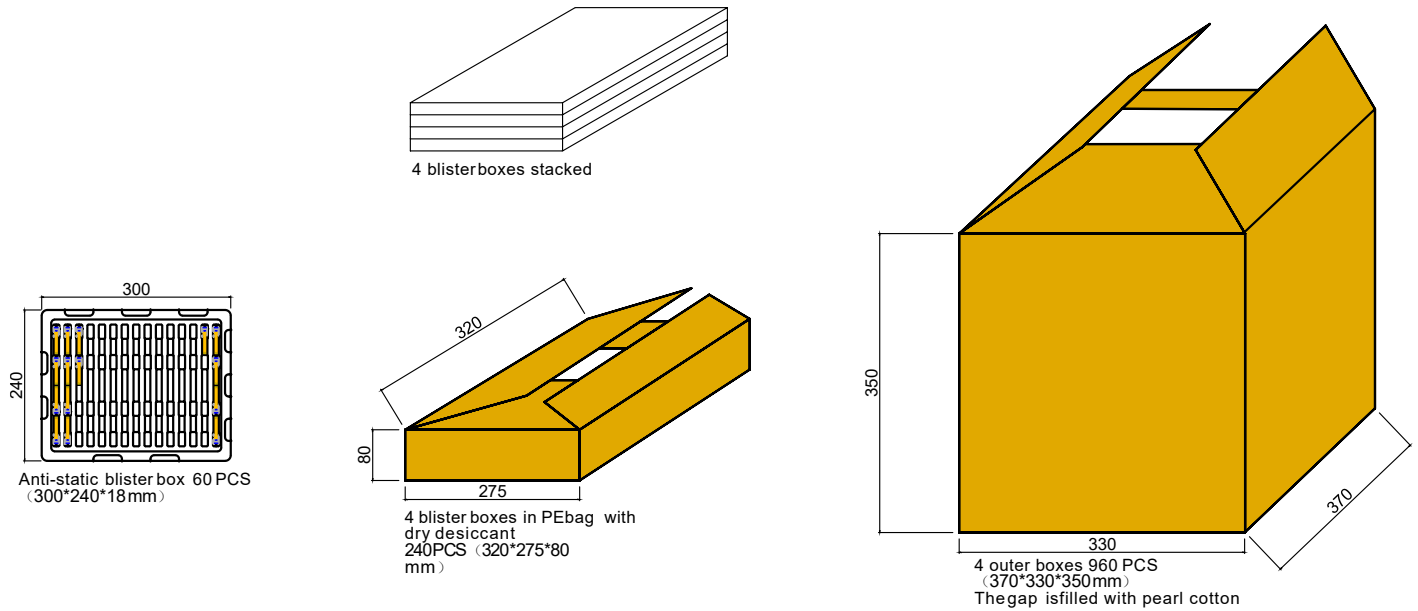

Table 8.4: Ordering Information

Model Number	Quantity per Box
SKM1600	960

## 9. Reliability Specifications

The sensitivity of each microphone in the module assembly must deviate by no more than 3 dB after each test. The microphone components themselves have passed the standard microphone reliability tests listed in their respective datasheets ([SKR0600](#) and Merry MMA206-019).

Test	Test Condition	Standard
Humidity Soak	+85 °C / 93 % R.H., 240 hours	IEC 60068-2-78
Thermal Shock	100 cycles, air-to-air, -40 °C to +85 °C, 30 minutes soak	JESD22.A104-F
High Temperature Storage	+85 °C for 96 hours	JESD22 A-103-B
Low Temperature Storage	-40 °C for 96 hours	JESD22-A119A
Drop (Package)	Modules packaged in standard shipping box, drop from 1 m, 10 drops in total.	ASTM D4169-22
Vibration (Package)	Modules packaged in standard shipping box, apply truck spectrum for 13 minutes and 20 seconds along each axis, then apply air spectrum for 2 hours.	ASTM D4169-22

## 10. Additional Support

For additional design and applications support, please reach out to [applications@soundskrit.ca](mailto:applications@soundskrit.ca).

Soundskrit provides a suite of DSP algorithms to take full advantage of the utility our microphones provide. With a range from lightweight linear DSP tools to multichannel, machine learning based processing, we have a solution to meet any performance requirements. For more software information, contact us or head to <https://soundskrit.ca/software>.

## 11. Revision History

Revision Label	Revision Date	Sections Revised
A	September 2025	Release



Soundskrit developed the first high-performance directional MEMS microphone on the market, leveraging years of research in bio-inspired MEMS based on how spiders and other insects in nature hear. In combination with Soundskrit's in-house audio processing algorithms, directional microphones can be used to capture and isolate any sound in an environment with a fraction of the size, power, and computation of traditional omnidirectional-based microphone arrays.

Soundskrit was founded in 2019 and is headquartered in Montreal, Quebec with an R&D facility in Ann Arbor, Michigan.

