

## 1. Characteristics

- Dipole polar pattern
- 65.5 dBA SNR
- 4.4 dB DI
- Single-ended output
- Integrated meshes for IPX7 with compressible sealing foam
- Pre-tested for >20 dB sealing
- Two sound ports on same surface
- 115  $\mu$ A supply current
- 16.00 x 4.00 x 4.85 mm<sup>3</sup>

## 2. Applications

- AR & VR Devices
- Tabletop Microphones
- Conferencing Devices
- Webcams
- Security Cameras
- Headsets
- Voice Badges
- Intercoms
- Smart Speakers
- Smart TVs

## 3. Description

The SKM2600 is a plug-and-play analog MEMS-based directional microphone module for consumer electronics. It is based on the [Soundskrit 0600 analog MEMS directional microphone](#). The module incorporates all acoustic design requirements necessary to properly integrate a directional microphone into products and bring both sound ports of the microphone onto the same surface. It also comes with a built-in Saati Acoustex 42Rayl mesh over each sound port. Customers can get premier audio pickup up and running in their end products with minimum hassle.

The SKM2600 will be available with dipole and hypercardioid variants to allow users to select their preferred beam pattern.

## 4. Dimensions

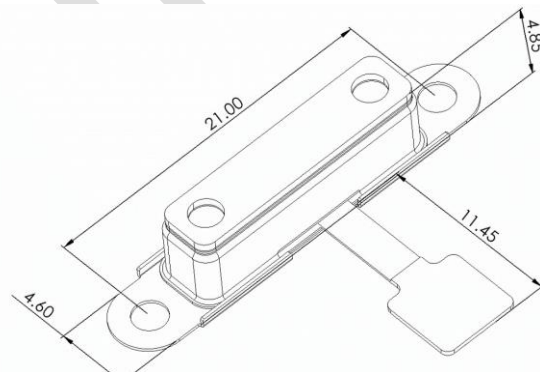

## 5. Design Features

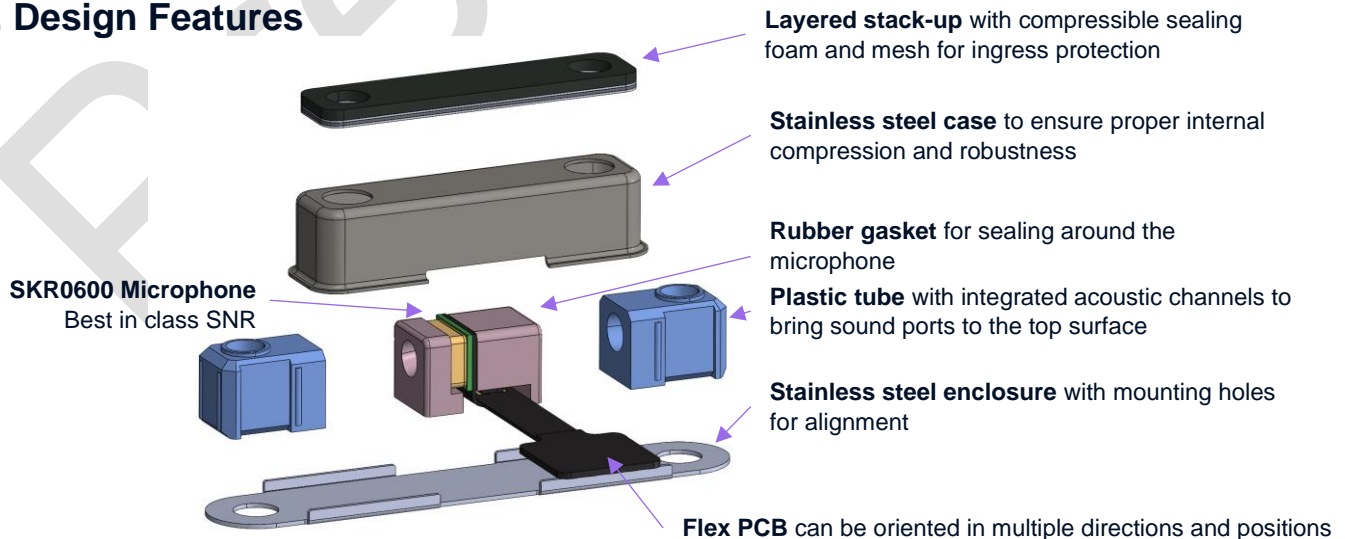

## 6. Table of Contents

1. Characteristics .....	1
2. Applications.....	1
3. Description .....	1
4. Dimensions .....	1
5. Design Features.....	1
6. Table of Contents.....	2
7. Typical Application Circuit .....	3
8. Specifications.....	4
8.1 Acoustic and Electrical Specifications .....	4
8.2 Specification Calculation Details .....	4
Directivity Index and Average Directivity Index Calculation .....	4
SNR Calculation .....	5
THD Calculation.....	5
8.3 Absolute Maximum Ratings.....	5
8.4 Performance Curves.....	6
9. Mechanical Drawings and Integration Design.....	8
9.1 Mechanical Drawings and Pinout .....	8
9.2 CAD Models .....	9
10. Reliability Specifications.....	9
11. Additional Support.....	9
12. Revision History .....	9

## 7. Typical Application Circuit

The module can be operated with  $V_{dd}$  from 1.6 – 2.0 V and 2.2 – 3.6 V.  $V_{dd}$  should not be set from 2.0 V – 2.2 V.

A 0.1  $\mu\text{F}$  capacitor between  $V_{dd}$  and GND is included on the flex cable of the module to reduce supply noise.

A capacitor  $C_{out}$  should be used to block each microphones output DC from the application processing input. This capacitor creates a high-pass filter according to  $C_{out} = 1/\pi f_c R_{AP}$  (e.g. 80 nF), where  $f_c$  (e.g. 20 Hz) is the desired cutoff frequency and  $R_{AP}$  (e.g. 100 kOhm) is the application processor resistance.

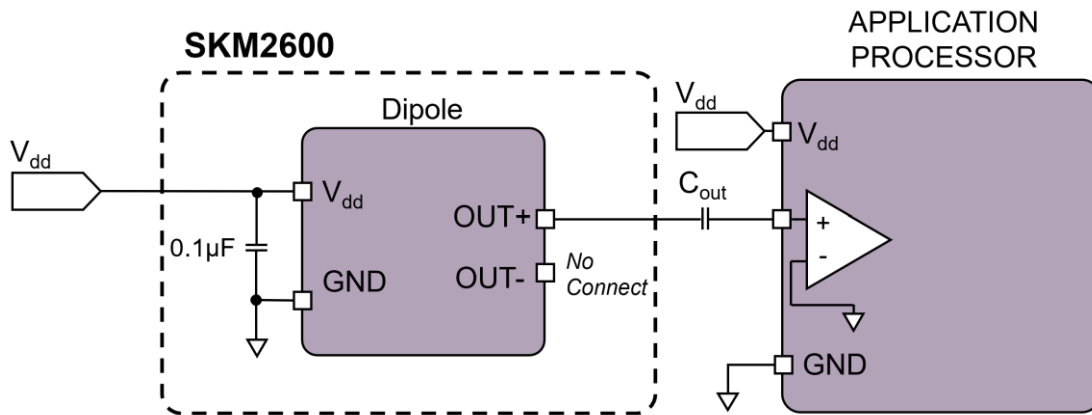

Figure 7.1: Typical application circuit

## 8. Specifications

Test conditions throughout full datasheet unless otherwise indicated: 25 °C, 55 ± 20% R.H.,  $V_{dd} = 1.8\text{ V}$ , 3 m away, no load, dipole PCB port facing toward loudspeaker and defined as 0°.

### 8.1 Acoustic and Electrical Specifications

Parameter	Symbol	Condition	Min.	Typ.	Max.	Unit
Pickup Pattern			Dipole			
Polarity		Increasing sound pressure at lid port (180°)	Increasing output voltage			
		Increasing sound pressure at PCB port (0°)	Decreasing output voltage			
Average Directivity Index		Integrated from 20 Hz to 20 kHz	4.4			dB
Null Angle			90, 270			°
Supply Voltage	$V_{dd}$		1.7	1.8	2.0	V
			2.2	2.8	3.6	
Supply Current	$I_{dd}$	$V_{dd} = 1.8\text{ V}$	115			µA
Sensitivity	S	94 dB SPL, 1 kHz	-32	-31	-30	dBV/Pa
Noise Floor			-92.5			dBV(A)
Signal to Noise Ratio <sup>1</sup>	SNR	20 Hz to 20 kHz, 94 dB SPL	65.5			dB(A)
Total Harmonic Distortion <sup>2</sup>	THD	94dB SPL, 1kHz	<0.1			%
		1% THD, 1 kHz	108			dB SPL
Acoustic Overload Point	AOP	10% THD, 1 kHz	128			
Resonant Frequency	Fres		3.0			kHz
Power Supply Rejection Ratio	PSRR	200 mV <sub>pp</sub> sine wave on $V_{dd}$ at 1 kHz	67			dB
Power Supply Rejection	PSR+N	200 mV <sub>pp</sub> 7/8 duty cycle rectangular waveform @ 217 Hz on $V_{dd}$ , A-weighted, BW = 22.4kHz	-85			
DC Voltage Output		$V_{dd} = 1.8\text{ V}$	0.836			V
Output Impedance	$Z_{out}$		100			Ω
Startup Time		Sensitivity within 1 dB of final value, outputs AC coupled	15			ms

### 8.2 Specification Calculation Details

#### Directivity Index and Average Directivity Index Calculation

The directivity index measures the ratio of the microphone output for a sound positioned directly in front of the microphone ( $\theta = 0^\circ$ ) versus sound with the same amount of total acoustic power coming from all directions equally. The directivity index at each frequency is calculated with the equation below.

$$DI = 10 \log_{10} \left( 4 \frac{\text{amplitude}(\theta = 0)^2 \left[ \frac{V^2}{Pa^2} \right]}{\int_0^{2\pi} \text{amplitude}(\theta)^2 \left[ \frac{V^2}{Pa^2} \right] |\sin \theta| d\theta} \right)$$

Equation 8.1: Directivity Index

The average directivity index is calculated by logarithmically weighting the directionality index at each frequency and then taking the average of these weighted values from 20 Hz to 20 kHz. For more information, refer to the app note: [AN-110: Attributes of Soundskrit Directional Microphones](#).

<sup>1</sup> A directional microphone has a non-flat frequency response, as such the SNR must be calculated for the entire frequency range. See [SNR Calculation](#) for details.

<sup>2</sup> To calculate the THD of a microphone with a non-flat frequency response, the frequency response must first be equalized. See [THD Calculation](#) for details.

## SNR Calculation

The SNR of a directional microphone with a non-flat frequency response must be calculated differently than the typical method used for omnidirectional microphones that have a flat frequency response. Instead of only using the 1 kHz sensitivity, the electrical noise of the microphone at each frequency (units of  $V^2/Hz$ ) must be divided by the corresponding sensitivity squared at each frequency (units of  $V^2/Pa^2$ ) to obtain the input referred acoustic noise at each frequency (units of  $Pa^2/Hz$ ). Then, the acoustic noise is A-weighted by multiplying it by the A-weighting factor ( $A_w$ ) and this A-weighted acoustic noise is integrated over the full audio bandwidth and converted to an equivalent sound pressure level (dBA SPL) by dividing by the reference pressure ( $P_{ref}=20 \mu Pa$ ). Finally, the SNR is calculated by subtracting the integrated input referred noise from 94 dB SPL. The equation for the calculation is shown below. For more information, refer to the app note: [AN-110: Attributes of Soundskrit Directional Microphones](#).

$$SNR = 94 - 20 \log_{10} \left( \frac{1}{P_{ref}^2 [Pa^2]} \int_{20Hz}^{20kHz} \frac{noise \left[ \frac{V^2}{Hz} \right]}{sensitivity \left[ \frac{V^2}{Pa^2} \right]} A_w df [Hz] \right)$$

Equation 8.2: Full-spectrum SNR calculation

## THD Calculation

THD is calculated by playing an acoustic sine wave at a specific sound pressure level and frequency and dividing the sum of the powers of the harmonic components of the captured signal by the power of the fundamental frequency. To calculate the THD of a microphone with a non-flat frequency response, the response must first be equalized to equally weigh the fundamental frequency and its respective harmonics. For more information on equalization and THD calculation, refer to the app note: [AN-110: Attributes of Soundskrit Directional Microphones](#).

## 8.3 Absolute Maximum Ratings

Meeting or exceeding the conditions listed as Absolute Maximum Ratings could permanently damage the devices. Operating the devices at these ratings could impact device reliability.

Parameter	Absolute Maximum Rating	Unit
$V_{dd}$ to GND	5.0	V
Input Current	$\pm 5$	mA
Storage Temperature	-40 to 85	$^{\circ}C$
Operating Temperature	-40 to 85	$^{\circ}C$

### 8.4 Performance Curves

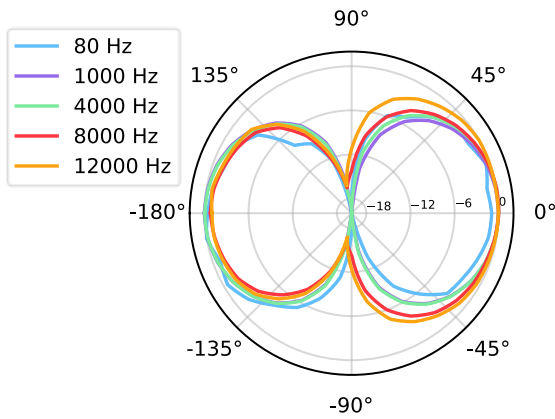

Figure 8.1: Polar pattern

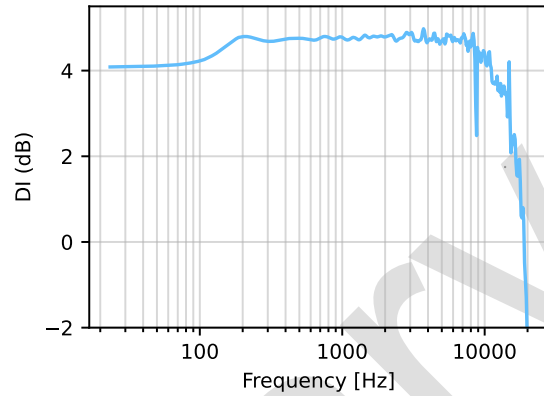

Figure 8.2: Directionality index vs frequency

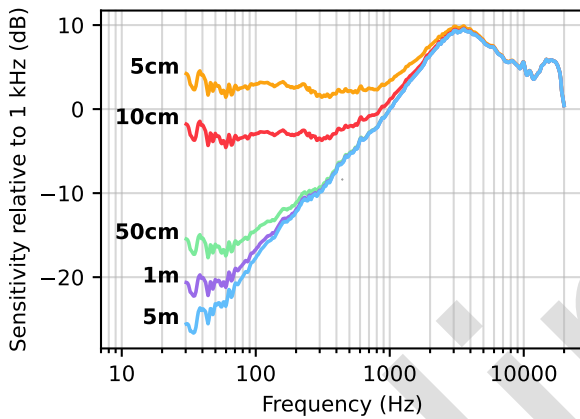

Figure 8.3: Magnitude response<sup>3</sup>

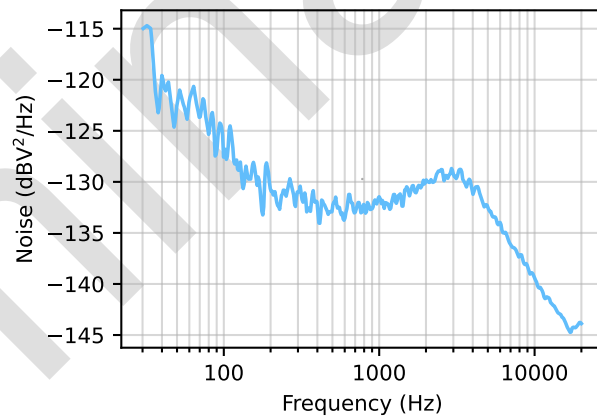

Figure 8.4: Noise floor

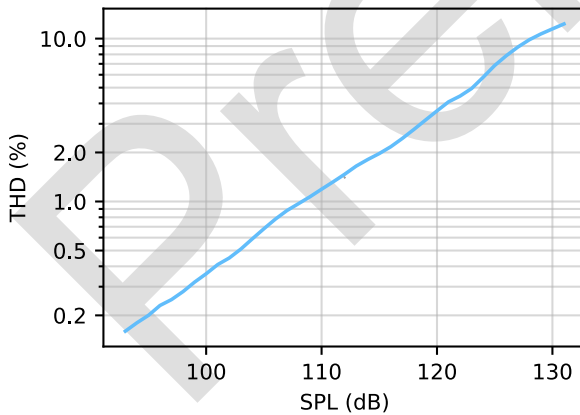

Figure 8.5: 1 kHz THD vs SPL

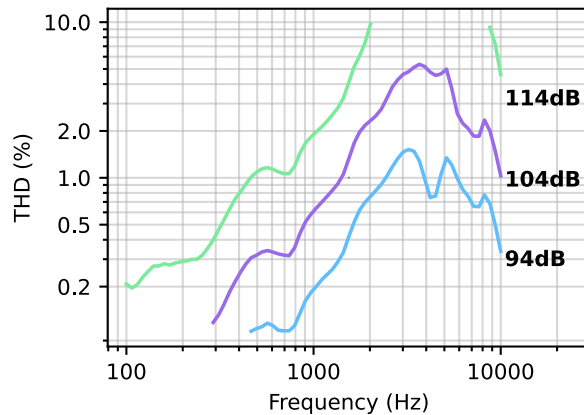

Figure 8.6: THD vs frequency

<sup>3</sup> The increased bass response at close distances is known as the 'Proximity Effect.' See [AN-110](#) for details.

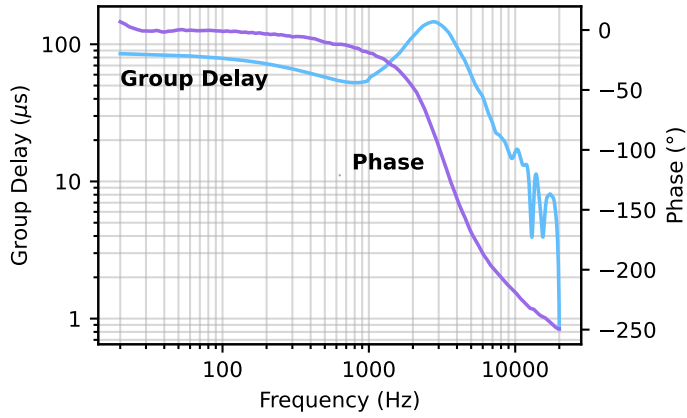

Figure 8.7: Phase and group delay

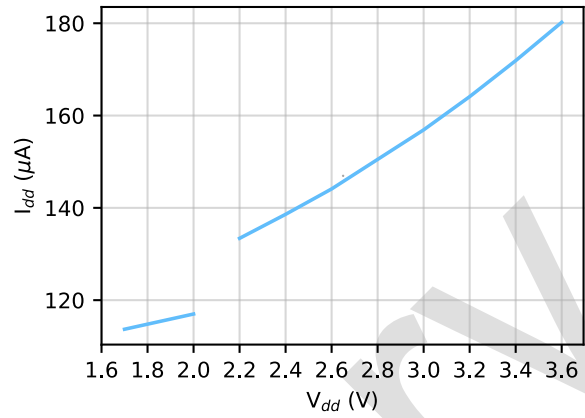

Figure 8.8: Input voltage vs supply current

Preliminary

## 9. Mechanical Drawings and Integration Design

### 9.1 Mechanical Drawings and Pinout

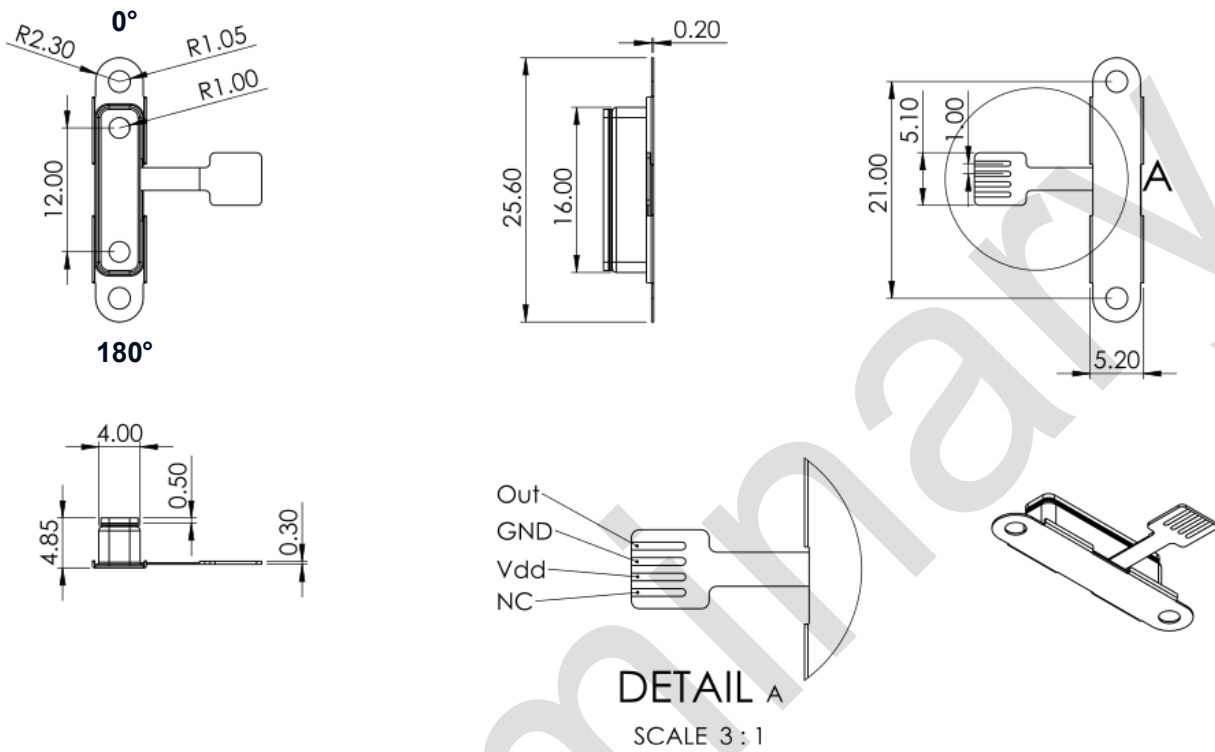

Figure 9.1: Mechanical drawings (mm)

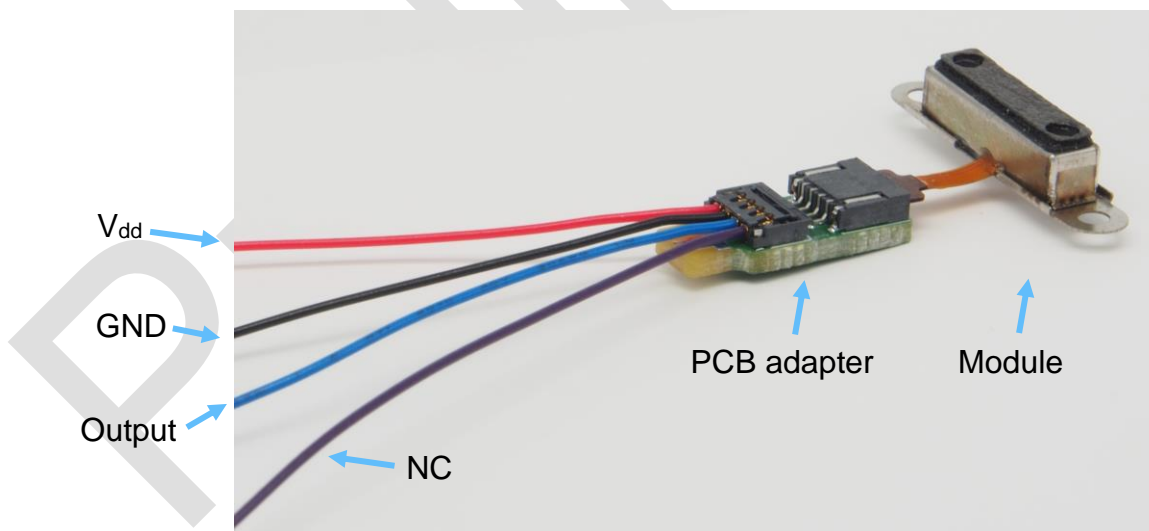

Figure 9.2: Pinout

Example mating connector: [Amphenol ICC \(FCI\) HFW4R-1STE1H1LF](#)

## 9.2 CAD Models

The CAD model for the module is available here: [SKM2600 STEP File](#)

## 10. Reliability Specifications

The sensitivity of the microphone in the module assembly must deviate by no more than 3 dB after each test. The microphone component itself has passed the standard microphone reliability tests listed in its datasheet ([SKR0600](#)).

Test	Test Condition	Standard
Humidity Soak	+85 °C / 93 % R.H., 240 hours	IEC 60068-2-78
Thermal Shock	100 cycles, air-to-air, -40 °C to +85 °C, 30 minutes soak	JESD22.A104-F
High Temperature Storage	+85 °C for 96 hours	JESD22 A-103-B
Low Temperature Storage	-40 °C for 96 hours	JESD22-A119A
Drop (Package)	Modules packaged in standard shipping box, drop from 1 m, 10 drops in total.	ASTM D4169-22
Vibration (Package)	Modules packaged in standard shipping box, apply truck spectrum for 13 minutes and 20 seconds along each axis, then apply air spectrum for 2 hours.	ASTM D4169-22

## 11. Additional Support

For additional design and applications support, please reach out to [applications@soundskrit.ca](mailto:applications@soundskrit.ca).

Soundskrit offers a suite of software algorithms to take full advantage of the utility our microphones provide. With a range from lightweight linear DSP tools to multichannel, machine learning based processing, we have a solution to meet any performance requirements. For more information, contact us or head to <https://soundskrit.ca/software>.

## 12. Revision History

Revision Label	Revision Date	Sections Revised
-	June 2024	Preliminary release



Soundskrit developed the first high-performance directional MEMS microphone on the market, leveraging years of research in bio-inspired MEMS based on how spiders and other insects in nature hear. In combination with Soundskrit's in-house audio processing algorithms, directional microphones can be used to capture and isolate any sound in an environment with a fraction of the size, power, and computation of traditional omnidirectional-based microphone arrays.

Soundskrit was founded in 2019 and is headquartered in Montreal, Quebec with an R&D facility in Ann Arbor, Michigan.

