



1. Characteristics

- Supercardioid polar pattern
 - 5.5 dB DI
 - 9.2 dB UI
- 74 dBA SNR
- Flat frequency response
- Ultra compact form factor
 - 7 mm diameter
 - 4.6 mm thickness
- Compatible with two-wire circuits for headsets or laptops
- Internal pop filter

2. Description

This document describes how to design a state-of-the-art boom microphone using the [SKR0600 Analog MEMS directional microphone](#). A 74 dBA SNR analog boom microphone is achieved without any software required. An acoustic mesh is used to create a supercardioid polar pattern. Additionally, a passive analog circuit is used to flatten the frequency response and make the microphone compatible with two-wire circuits often used by the audio jack in headsets, laptops, and gaming controllers.

Due to the high SNR of the SKR0600, the boom design can be made as small as 7mm in diameter and 4.6mm in thickness. This makes it ideal for applications in which small, sleek boom designs are required. The industrial design, including the outer shape and inner dimensions, is flexible as long as the key parameters are followed. Measurements are provided for a prototype of the design and samples of this prototype are available upon request.



Figure 2.1: Product render of the SKR0600 boom microphone reference design and cutout

3. Performance Curves

Test conditions unless otherwise indicated: 25 °C, 55 ± 20% R.H., $V_{bias} = 2.2\text{ V}$, $R_{bias} = 2.2\text{ k}\Omega$, 5 cm away, PCB port facing toward loudspeaker and defined as 0°.

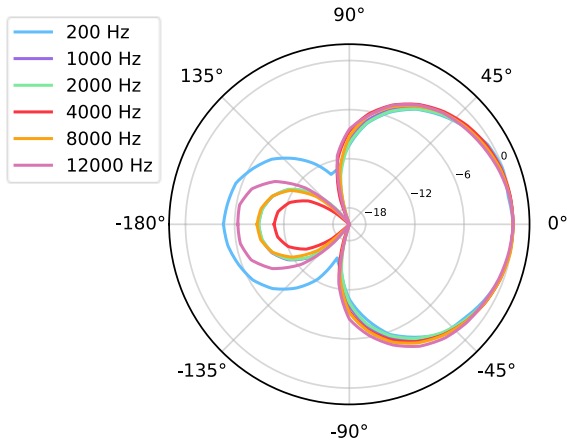

Figure 3.1: Pickup pattern vs frequency

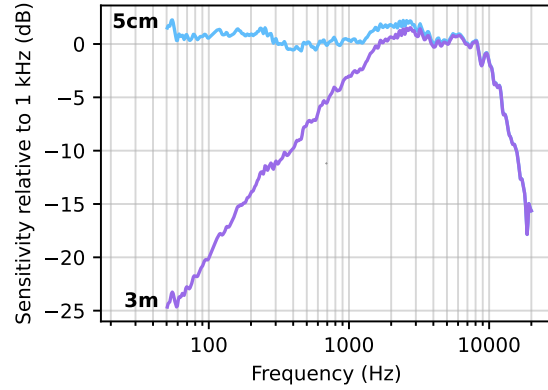

Figure 3.2: Sensitivity vs frequency

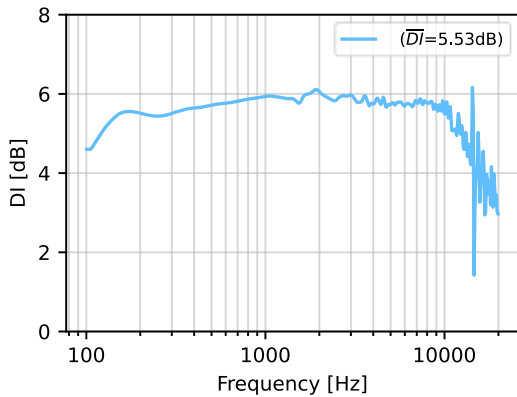

Figure 3.3: Directionality index vs frequency

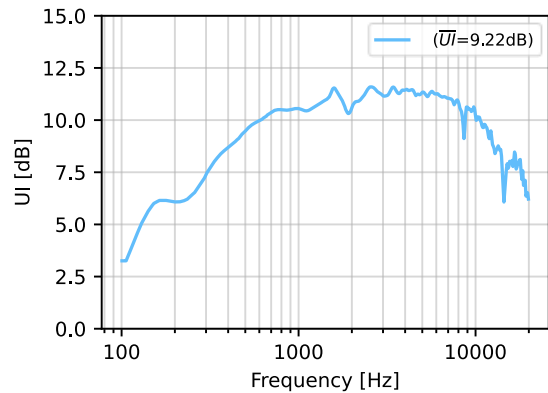

Figure 3.4: Unidirectional index vs frequency

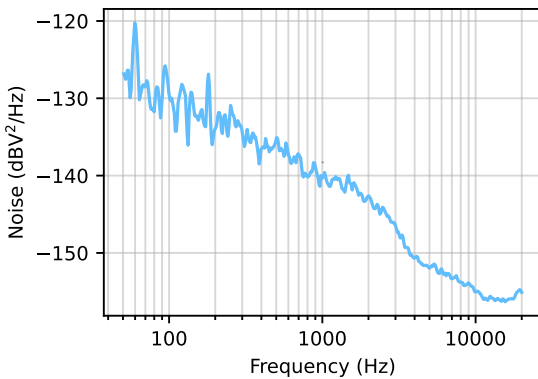

Figure 3.5: Noise floor

4. Electrical Design

A two-stage circuit based on seven passive components makes the SKR0600 compatible with boom microphone applications.

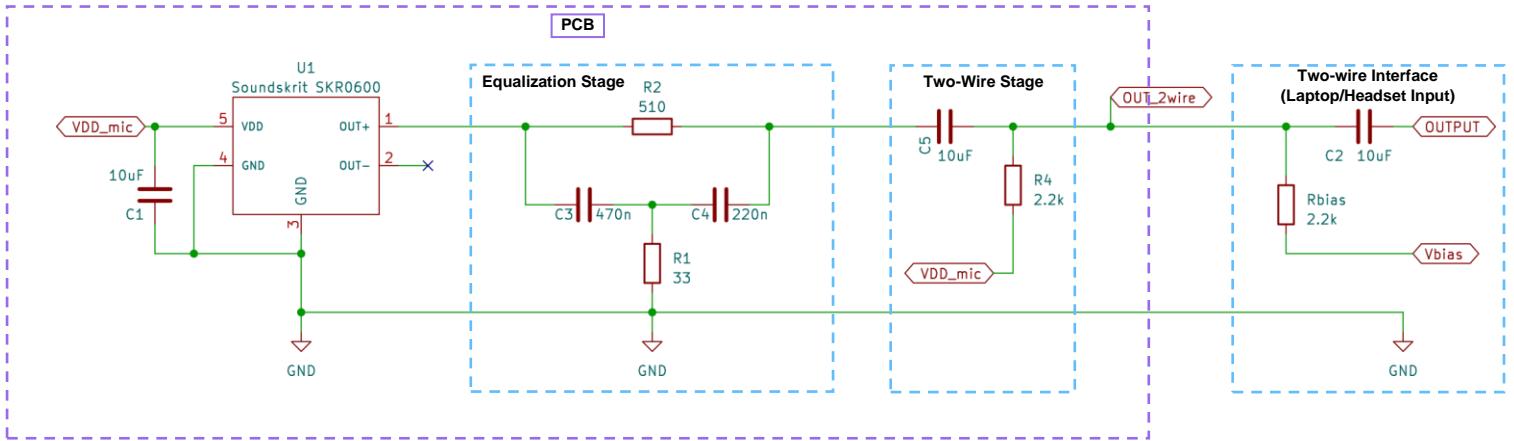

Figure 4.1: SKR0600 electrical two-stage circuit

The first stage, the equalization stage, is a notch filter that flattens the frequency response of the microphone so that its sensitivity is the same at all frequencies (see Figure 4.1). The filter shown above is optimized to give a flat frequency response when the microphone is 5cm from the user’s mouth. If certain design parameters are changed, the values may need to be re-tuned.

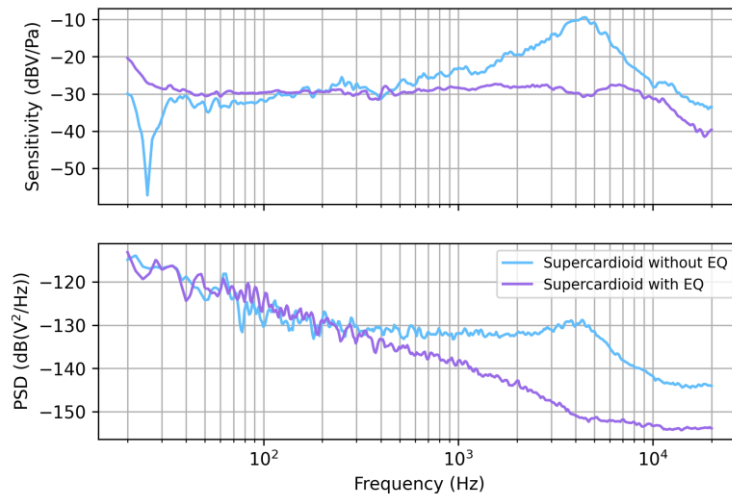

Figure 4.2: Frequency response at 5 cm with and without EQ circuit.

The second stage, the two-wire stage, enables compatibility with the two-wire input circuits typically used with electret microphones connecting to headsets and laptops. The two components in this stage allow a single wire (OUT_2wire) to both power the microphone and carry the microphone output (OUT+) to the input of the headset or laptop. The values of the components are tuned for the [Android 3.5 mm headset specification](#), which is based on a headset or laptop supply of $V_{bias} = 2.2\text{ V}$ and input resistance of $R_{bias} = 2.2\text{ k}\Omega$. Since $V=IR$ and $I_{mic} = 115\text{ }\mu\text{A}$, we can write $V_{dd_{mic}} = V_{bias} - I_{mic}(R_4 + R_{bias}) = 1.7\text{ V}$, which is close to the center operating voltage range of the SKR0600 (1.6 V to 2.0 V). Large 10 μF values are recommended for C1 and C2 to ensure stable voltage and no added supply noise to the microphone.

To learn more about the two-wire circuit, see our app note [AN-520: Two-wire Configuration to use MEMS with ECM Circuits](#).

5. Mechanical Overview

5.1 Exploded View

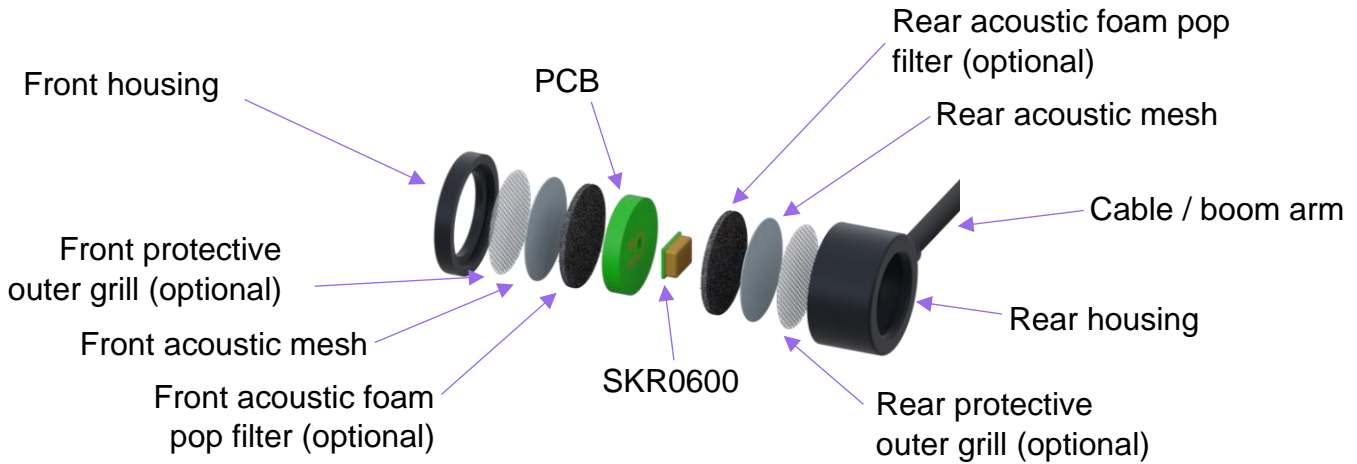

Figure 5.1: Exploded View

5.2 Design parameters

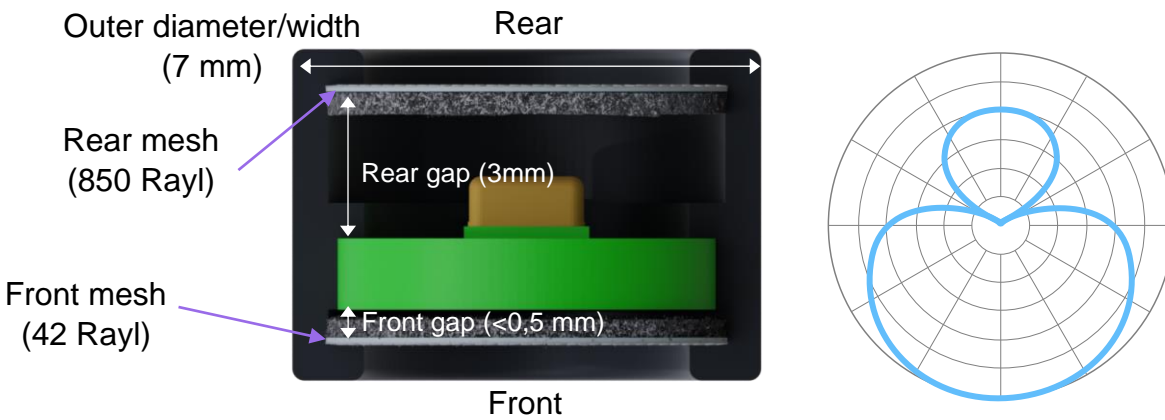

Figure 5.2: Cross section and polar pattern orientation

Parameter	Value	Notes
Outer diameter/width	7 mm	The diameter or width of the boom casing. A larger diameter or width will increase SNR while a smaller diameter will decrease SNR. Changing the diameter will affect the flatness of the frequency response and the shape of the polar pattern. It may require a retuning of the equalization stage and the rear mesh impedance to achieve the desired specifications.
Rear gap	3 mm	The distance from the front of the PCB to the rear acoustic mesh. Changing this distance will affect the shape of the polar pattern and may require a retuning of the rear mesh impedance to achieve the desired specifications.
Front gap	<0.5 mm	The distance from the back of the PCB to the front acoustic mesh. This gap can be minimized since it has negligible impact on performance.
Front and back protective outer grills	N/A	An optional metal mesh can be used to protect the openings of the microphone. It should be highly perforated to be as acoustically transparent as possible.
Front mesh impedance	≤42 Rayl	A front acoustic mesh is used for ingress protection. The Saati 042HY (with hydrophobic coating) is recommended for IP57.
Rear mesh impedance	750 Rayl	A rear acoustic mesh is used to create an acoustic delay between the front and back ports of the microphone and change the polar pattern from a dipole to a supercardioid. The Bopp AM750 with HC8 (hydrophobic coating) is recommended and will also provide IP57.
Acoustic foam	50-80 ppi	An optional acoustic foam can be used to create a pop filter.

5.3 Prototype image and pinout

The prototype can be used in a two-wire configuration by connecting OUT_2wire (which carries $V_{bias}=2.2V$ and the microphone output) and GND to the input of the headset or laptop. Alternatively, it can be used in a three-wire configuration by connecting V_{dd} to V_{dd_mic} , GND to GND and the input of the acquisition system to OUT_2wire.

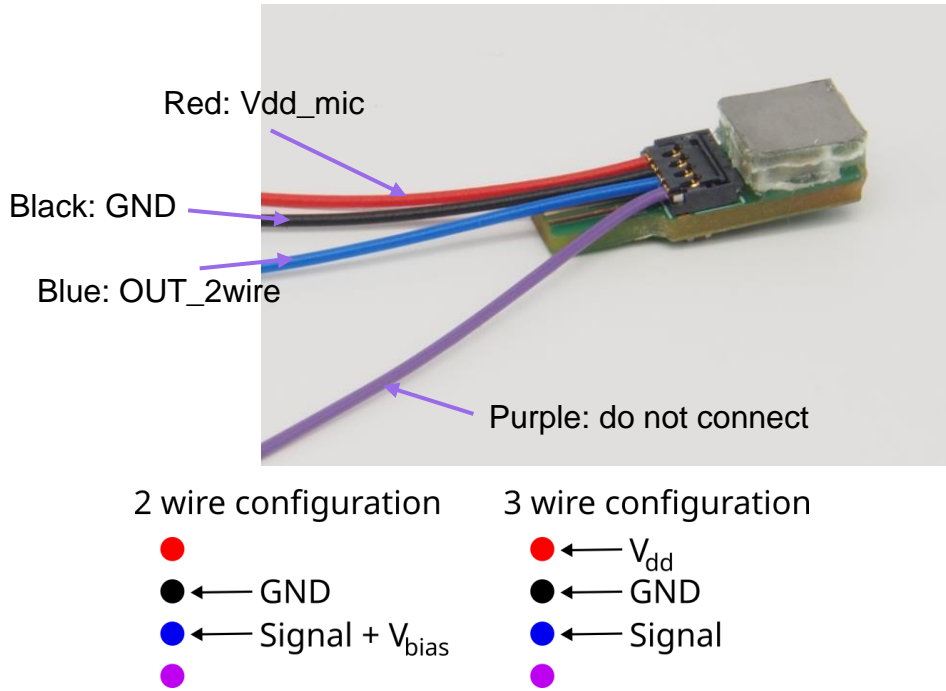

Figure 5.3: Connection overview.

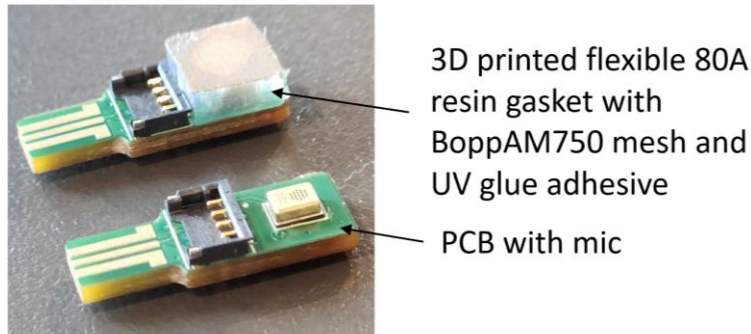

Figure 5.4: Cardioid and dipole on coupon PCB.

6. Device and Documentation Support

6.1 Datasheets

[SKR0600 Datasheet](#)

6.2 Application Notes

The application notes referred to in this document can be found on our [application notes page](#):

- AN-100: Comparing Soundkrit Directional Microphones to Omnidirectional Microphones
- AN-110: Attributes of Soundkrit Directional Microphones
- AN-210: Designing Linear Arrays with Directional Microphones
- AN-520: Two-wire Configuration to use MEMS with ECM Circuits

7. Revision History

Revision Label	Revision Date	Sections Revised
-	April 2024	Initial release
A	May 2024	Revised format and specifications based on smaller prototype
B	June 2024	Revised circuit image in Figure 4.1 and clarified wiring in 5.3



Soundskrit developed the first high-performance directional MEMS microphone on the market, leveraging years of research in bio-inspired MEMS based on how spiders and other insects in nature hear. In combination with Soundskrit's in-house audio processing algorithms, directional microphones can be used to capture and isolate any sound in an environment with a fraction of the size, power, and computation of traditional omnidirectional-based microphone arrays.

Soundskrit was founded in 2019 and is headquartered in Montreal, Quebec with an R&D facility in Ann Arbor, Michigan.

